

Cowherd, Jr. C [1990]. Open fugitive dust—PM10 sources and controls. EPA-OAQPS, Sacramento, CA.  
<https://nepis.epa.gov/Exe/ZyPDF.cgi/94000PUK.PDF?Dockey=94000PUK.PDF>

Defibaugh J [2020]. E-mail message from Joe Defibaugh, PDTC Group Leader, Komatsu Mining Corp. to Jay Colinet, NIOSH, May 18.

Defibaugh J [2021]. E-mail message from Joe Defibaugh, PDTC Group Leader, Komatsu Mining Corp. to Jay Colinet, NIOSH, January 4.

Doney BC, Blackley D, Hale JM, Halldin C, Kurth L, Syamlal G, Laney AS [2019]. Respirable coal mine dust in underground mines, United States, 1982–2017. *Am J Ind Med* 62(6):478–485.

EIA [2019]. Annual coal report 2018. Washington DC: U.S. Department of Energy, Energy Information Administration. <https://www.eia.gov/coal/annual/pdf/acr.pdf>

EIA [2020]. Annual coal report (multiple years accessed). Washington DC: U.S. Department of Energy, Energy Information Administration. <https://www.eia.gov/coal/annual/>

Fiscor S [2019]. Longwall production remains steady; 2019 U.S. longwall census. *Coal Age* 124(1):24–28.

Grigal D, Ufken G, Sandstedt J, Blom M, Johnson D [1982]. Development of improved scrubbers for coal mine applications. U.S. Bureau of Mines OFR 91-83, NTIS PB 83-205385.

Jankowski RA, Kissell FN [1983]. Improved face ventilation lowers longwall dust levels. In: *Transactions of Society for Mining, Metallurgy, and Exploration, Inc.* Vol. 274. Littleton, CO: Society for Mining, Metallurgy, and Exploration, Inc., pp. 2024–2028.

Jankowski RA, Kissell FN, Daniel JH [1986]. Longwall dust control: an overview of progress in recent years. *Min Eng* 28(10):953–958.

Jankowski RA, Colinet JF [2000]. Update on face ventilation research for improved longwall dust control. *Min Eng* 52(3):45–52.

Jayaraman NI, Jankowski RA, Kissell FN [1985]. Improved shearer-clearer system for double-drum shearers on longwall faces. Pittsburgh, PA: U.S. Department of the Interior, Bureau of Mines, RI 8963. NTIS No. PB 86-107844.

Kelly J, Ruggieri S [1990]. Evaluate fundamental approaches to longwall dust control; subprogram C: Stageloader dust control. Foster-Miller, Inc. U.S. Bureau of Mines contract J0318097. NTIS No. DE 90-015510.

Klima SS, Reed WR, Driscoll JS, Mazzella AL [2020]. A laboratory investigation of underside shield sprays to improve dust control of longwall water spray systems. *Mining, Metallurgy & Exploration*, published online November 2, <https://doi.org/10.1007/s42461-020-00339-x>

Kost JA, Yingling JC, Mondics BJ [1981]. Guidebook for dust control in underground mining. Bituminous Coal Research Inc. U.S. Bureau of Mines contract J0199046. NTIS No. PB 83-109207.

Lechler [2020]. Solid stream nozzles.  
<https://www.lechlerusa.com/en/products/product-by-type/solid-stream-nozzles/>

Lindahl P ([Lindahl.Philip@DOL.GOV](mailto:Lindahl.Philip@DOL.GOV)) [2015]. RE: Vent/dust plans for LW faces. Private e-mail message to Jay Colinet ([JColinet@cdc.gov](mailto:JColinet@cdc.gov)), NIOSH, July 27.

Listak JM, Chekan GJ, Colinet JF [2001]. Laboratory evaluation of shield dust entrainment in high velocity airstreams. In: Transactions of Society for Mining, Metallurgy, and Exploration, Inc. Vol. 310. Littleton, CO: Society for Mining, Metallurgy, and Exploration, Inc., pp. 155–160.

Meikle GB ([Meikle.Gregory@DOLGOV](mailto:Meikle.Gregory@DOLGOV)) [2020]. RE: Use of belt air for face ventilation. Private e-mail message to Jay Colinet ([JColinet@cdc.gov](mailto:JColinet@cdc.gov)), NIOSH, March 11.

Midwest Research Institute [1981]. Dust control for haul roads. U.S. Department of the Interior, Bureau of Mines Open File Report 130-81.

MSHA [2020a]. MSHA data sets—3. Coal dust samples data set. U.S. Department of Labor, Mine Safety and Health Administration.  
<https://arlweb.msha.gov/OpenGovernmentData/OGIMSHA.asp>

MSHA [2020b]. MSHA data sets—16. Quartz samples. U.S. Department of Labor, Mine Safety and Health Administration. <https://arlweb.msha.gov/OpenGovernmentData/OGIMSHA.asp>

MSHA [2020c]. MSHA Handbook Series, Handbook Number: PH89-V-1 (27), Coal Mine Health Inspection Procedures. U.S. Department of Labor, Mine Safety and Health Administration.

NIOSH [2003]. Handbook for dust control in mining. By: Kissell FN. Pittsburgh, PA: U.S. Department of Health and Human Services, Centers for Disease Control and Prevention, National Institute for Occupational Safety and Health, DHHS (NIOSH) Publication No. 2003-147, Information Circular 9465.

Organiscak JA, Khair AW, Ahmad M [1996]. Studies of bit wear and respirable dust generation. In: Transactions of Society for Mining, Metallurgy, and Exploration, Inc. Vol. 298. Littleton, CO: Society for Mining, Metallurgy, and Exploration, Inc., pp. 1932–1935.

Pollock D, Organiscak J [2007]. Airborne dust capture and induced airflow of various spray nozzle designs. *Aer Sci Tech* 41(7):711–720.

Reed WR, Zheng Y, Klima S, Shahan MR, Beck TW [2017]. Experimental study of foam coverage on simulated longwall roof. In: Transactions of Society for Mining, Metallurgy, and Exploration, Inc. Vol. 342. Littleton, CO: Society for Mining, Metallurgy, and Exploration, Inc., pp. 77–82.

Reed WR, Beck TW, Zheng Y, Klima S, Driscoll J [2018]. Foam property tests to evaluate the potential for longwall shield dust control. *Min Eng* 70(1):35–41.

Reed WR, Shahan MR, Zheng Y, Mazzella A [2021]. Laboratory results of foam application testing for longwall shield dust control in a simulated environment. *Int J Coal Sci Tech*. Published online March 2. <https://doi.org/10.1007/s40789-021-00414-8>

Rider JP, Colinet JF [2007]. Current dust control practices on U.S. longwalls. In: Proceedings of Longwall USA, Pittsburgh, PA, June 5-7.

Rider JP, Colinet JF [2011]. Benchmarking longwall dust control technology and practices. *Min Eng* 63(9):74–80.

Ruggieri SK, Muldoon TL, Schroeder W, Babbitt C, Rajan S [1983]. Optimizing water sprays for dust control on longwall shearer faces. Foster-Miller, Inc. U.S. Bureau of Mines contract J0308019. NTIS No. PB 86-205408.

Schowengerdt FD, Brown JT [1976]. Colorado School of Mines tackles control of respirable coal dust. *Coal Age* 81(4):129–131.

Shankar S, Ramani RV [1995]. Effect of air velocity and walking on the re-entrainment of dust in mine airways. In: Transactions of Society for Mining, Metallurgy, and Exploration, Inc. Vol. 298. Littleton, CO: Society for Mining, Metallurgy, and Exploration, Inc., pp. 1834–1838.

Shirey CA, Colinet JF, Kost JA [1985]. Dust control handbook for longwall mining operations. BCR National Laboratory. U.S. Bureau of Mines contract J0348000. NTIS No. PB-86-178159/AS.

Spraying Systems Co. [2016]. Spray technology for dust control. Bulletin No. 652A. [https://www.spray.com/-/media/DAM/Sales-Materials/b/B652A\\_Spray\\_Technology\\_Dust\\_Control.pdf](https://www.spray.com/-/media/DAM/Sales-Materials/b/B652A_Spray_Technology_Dust_Control.pdf)

Stahura RP [1987]. Conveyor belt washing: Is this the ultimate solution? *TIZ-Fachberichte* 111(11):768–771.

Stahura RP [1997]. The pyramid of effective conveyor dust control: containment, suppression, and collection. International Materials Handling Conference, BeltCon 9, Midrand, South Africa, October 22–24, Paper 21.

Swinderman RT, Marti AD, Goldbeck LJ, Marshall D, Strebel MG [2013]. Foundations: the practical resource for cleaner, safer, more productive dust & material control, Fourth edition. Neponset, Illinois: Martin Engineering Company.

Tomb TF et al. [1992]. Evaluation of respirable dust control on longwall mining operations. In: Transactions of Society for Mining, Metallurgy, and Exploration, Inc. Vol. 288. Littleton, CO: Society for Mining, Metallurgy, and Exploration, Inc., pp. 1874–1878.

USBM [1981]. High-pressure shrouded water sprays for dust control. By Jayaraman NI, Kissell FN, Cross W, Janosik J, Odoski J. Pittsburgh, PA: U.S. Department of the Interior, Bureau of Mines, RI 8536. NTIS No. PB 81-231458.

USBM [1982]. Dust knockdown performance of water spray nozzles. Pittsburgh, PA: U.S. Department of the Interior, Bureau of Mines Technology News 150.

USBM [1984]. Reducing longwall face workers' respirable dust exposure from roof support movement. Pittsburgh, PA: U.S. Department of the Interior, Bureau of Mines Technology News 205.

USBM [1985]. Improved stageloader dust control in longwall mining operations. Pittsburgh, PA: U.S. Department of the Interior, Bureau of Mines Technology News 224.

USBM [1986]. Dust controls to improve quality of longwall intake air. By Organiscak JA, Jankowski RA, Kelly JS. Pittsburgh, PA: U.S. Department of the Interior, Bureau of Mines, IC 9114. NTIS No. PB 87-167573.

USBM [1989a]. Basic parameters of conveyor belt cleaning. By Rhoades CA, Hebble TL, Grannes SG. U.S. Department of the Interior, Bureau of Mines Report of Investigations 9221.

USBM [1989b]. Novel foam application lowers longwall dust. Pittsburgh, PA: U.S. Department of the Interior, Bureau of Mines Technology News 326.

USBM [1992]. Dust considerations when using belt entry air to ventilate work areas.  
By Potts JD, Jankowski RA. Pittsburgh, PA: U.S. Department of the Interior, Bureau of Mines,  
RI 9426.

Wang H, Wang D, Wang Q, Jia Z [2014]. Novel approach for suppressing cutting dust using  
foam on a fully mechanized face with hard parting. *J Occ Env Hyg* 11(3):154–164.

## CHAPTER 4: CONTROLLING RESPIRABLE DUST ON CONTINUOUS MINING SECTIONS

Historically, average dust concentrations found on continuous miner sections have been lower than those found on longwall sections. Figure 3.1 shows that this trend has continued over the past 10 years. However, exposure to respirable crystalline silica (quartz) dust is a major concern on continuous mining sections, with the largest source of this quartz typically being the rock strata overlaying (Figure 4.1, left) or underlying the coal seam. For continuous mining operations, extraction of this rock is often needed for equipment clearance but can lead to increased dust generation as shown in Figure 4.1, right [Beck et al. 2016]. Likewise, roof bolter operators must drill into roof rock in order to anchor roof supports.

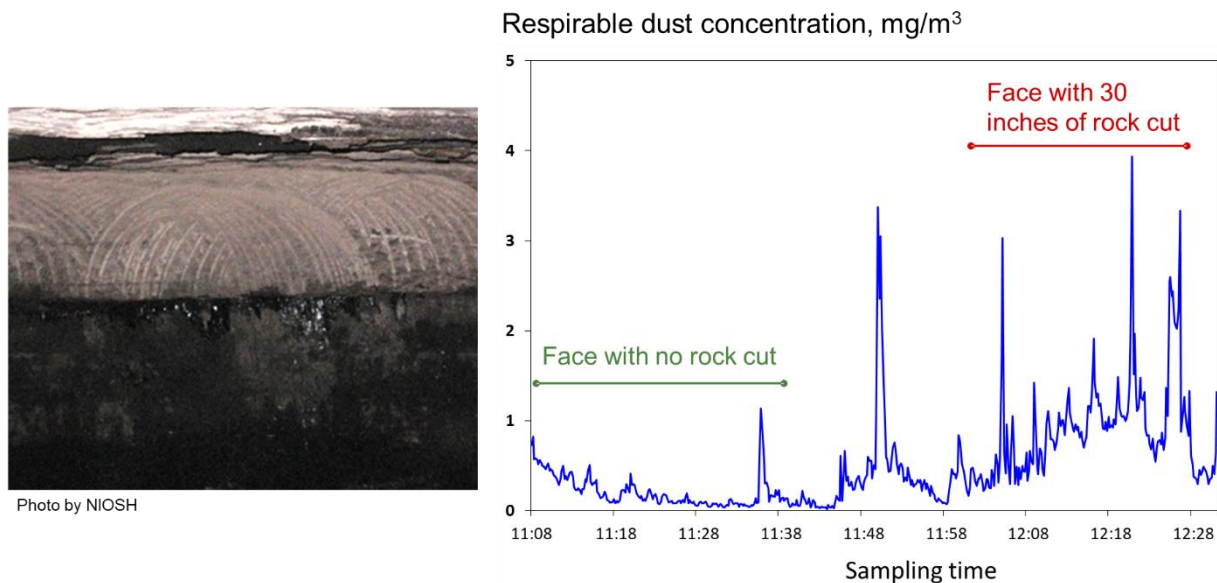

**Figure 4.1. Photo (left) showing approximately 18 inches of roof rock extracted as part of mining and line graph (right) showing increased respirable dust generation when mining rock.**

To illustrate the concern with exposure to respirable quartz on continuous mining sections and the increasing impact on miners' health, three NIOSH studies are discussed. In the first study, 19 former miners that worked in Central Appalachian mines and had been diagnosed with severe lung disease (progressive massive fibrosis) were interviewed to learn about their work history [Reynolds et al. 2018]. Sixteen of these miners indicated that their primary jobs were operating continuous miners (7) or roof bolters (9), with two other miners indicating they did a combination of these jobs. In the second study that was initially cited in Chapter 1, health surveillance data indicates that quartz's contribution to lung disease in miners from the Central Appalachian mining region has increased over the last several decades [Hall et al. 2019]. This region has a large concentration of continuous mining operations with this health data suggesting that as time has passed more rock is being extracted as the more desirable seams have been mined out. In the third study, NIOSH researchers collected information from Mine Safety and Health Administration (MSHA) inspector reports on the operating conditions at 67 mines in the Central Appalachian region [Pollock et al. 2010]. MSHA inspector data indicated that rock extraction typically accounted for between 20% and 30% of the mining height, with over half of the mines in this region on a reduced dust standard due to elevated quartz levels. Therefore,

controlling the quartz exposure for continuous miner (CM) and roof bolter (RB) operators must be a high priority.

Since passage of the Federal Coal Mine Health and Safety Act of 1969, federal coal mine inspectors have collected respirable dust samples that are analyzed for quartz content. From 1970 until the enactment of the 2014 dust rule [79 Fed. Reg. <sup>15</sup> 24814 (2014)], samples containing greater than 5% quartz were considered excessive and triggered calculation of a reduced dust standard for the mining section from which the sample was collected. On continuous mining sections, the high risk and most frequently sampled occupations were the CM operator, normally identified as the designated occupation (DO) sample, and the RB operator, normally identified as the designated area (DA) sample. Therefore, the 5% quartz metric will be used to assess the quartz content of respirable dust samples collected from CM and RB operators.

In an MSHA publication, inspector samples collected from 1988 through 1992 for RB operator occupations (twin-head RB intake and return side operators, mounted RB intake and return side operators, and single-head RB operators) and CM operators were analyzed for samples containing more than 5% quartz [Ainsworth et al. 1995]. NIOSH analyzed publicly available MSHA inspector samples collected from 2000 through 2020 for CM and RB operator samples containing more than 5% quartz [MSHA 2020a]. Data was omitted for the time period when sampling was transitioning from the implementation of the initial parts of the 2014 dust rule (August 1, 2014) to the lowering of the dust standard (August 1, 2016). The RB operator samples downloaded from the MSHA website contained the five RB occupations mentioned above. Figure 4.2 shows the percentage of inspector samples for CM and RB operators that contained greater than 5% quartz. For all periods, RB operator occupations experienced a higher percentage of samples exceeding 5% quartz than the CM operators. Notable increases for the RB operator samples were seen in the 2000s, before percentages for both RB and CM operators dropped in the 2010s. This data indicates that a substantial percentage of samples for these occupations have contained more than 5% quartz throughout this period.

Consequently, in MSHA's 2014 dust rule, the CM operator was specified as the DO and the RB operator as the other designated occupation (ODO) that must be sampled by mine operators on CM sections. Fifteen valid respirable dust samples must be collected on consecutive shifts for the DO and then the ODO each quarter. In addition, previous sampling data including NIOSH sampling [NIOSH 2011] has shown that haulage car operators (e.g., shuttle cars, ram cars) can be exposed to elevated dust levels when being loaded by the CM in sections using blowing ventilation. As a result, MSHA also requires the collection of 15 valid samples for haulage car operators in these sections. As part of this dust rule, a reduced dust standard is now calculated when a sample contains over 100 micrograms per cubic meter of air ( $\mu\text{g}/\text{m}^3$ ) of quartz as compared to the 5% quartz criteria previously discussed. The reduced dust standard is calculated with the same formula ( $10 \div \% \text{ quartz}$ ) as mentioned in Chapter 1, but the reduced standard cannot exceed the 1.5 milligrams per cubic meter of air ( $\text{mg}/\text{m}^3$ ) new dust standard.

---

<sup>15</sup> Federal Register. See Fed. Reg. in references.

## Inspector samples containing greater than 5% quartz, %

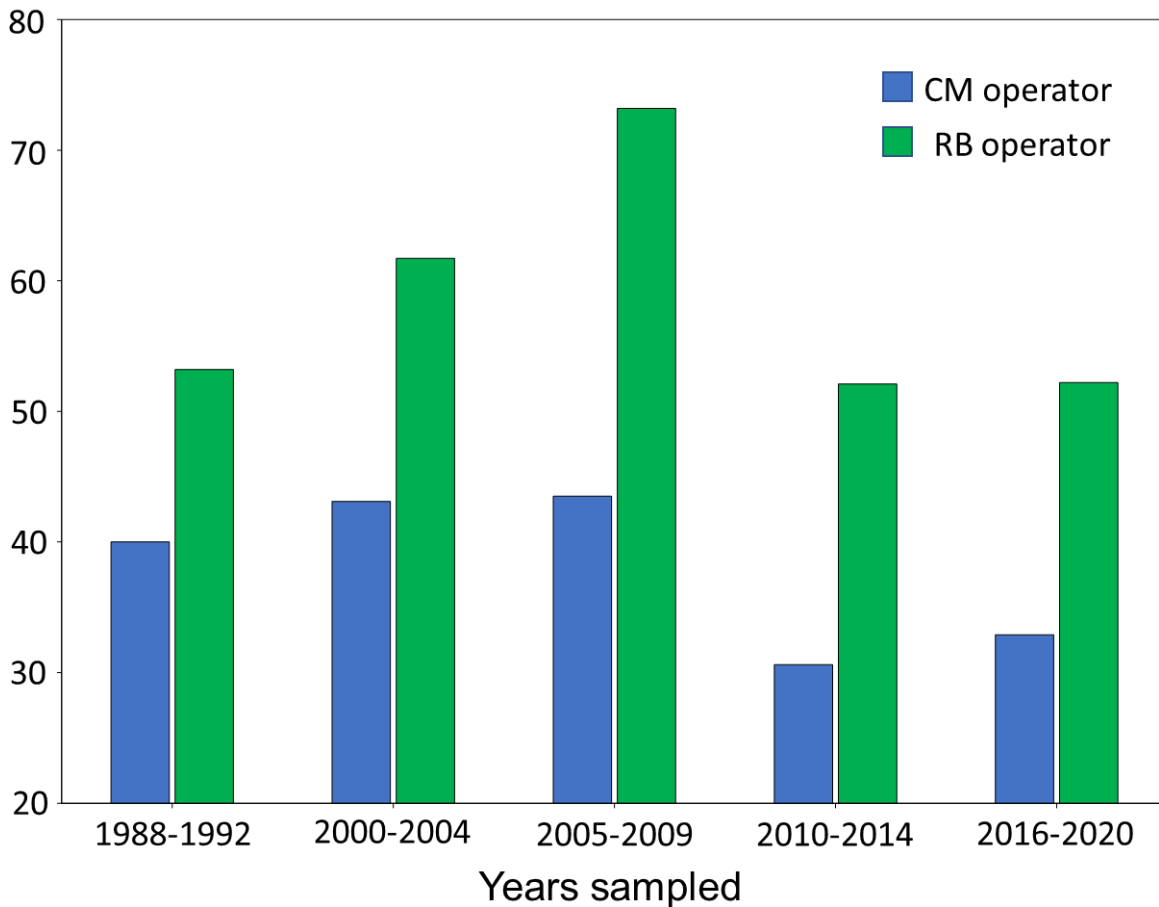

**Figure 4.2. Percentage of MSHA inspector dust samples analyzed for quartz from continuous miner and roof bolter operators that contained greater than 5% quartz.**

The two greatest sources of respirable dust exposure on CM sections are typically the CM and the RB. As noted in Chapter 3, ventilating air and water are the primary controls used to dilute, suppress, redirect, or capture dust in underground coal mining operations. In addition to these primary controls, powered dust collectors on CMs and RBs provide supplemental controls that have been proven to be highly effective in controlling respirable dust liberation from these machines. In this chapter, discussion of ventilation, water sprays, and powered dust collectors will be provided, along with information on other dust sources and controls found on continuous mining sections.

### Section Ventilation

Ventilating air is supplied to underground coal mines to provide fresh air for the miners to breathe and to dilute and remove airborne contaminants. For continuous mining sections, federal regulations [30 CFR 75.325 ] require a minimum air quantity at each working face of 3,000 cubic feet per minute (cfm), with a minimum quantity of 9,000 cfm required at the last open crosscut. Often, mining operations supply greater quantities of ventilating air at both locations, and these greater quantities are specified in a ventilation plan that must be approved by

MSHA. The ventilation plan quantities then become the minimum acceptable quantities and must be maintained or exceeded at all times. However, one goal of MSHA’s quarterly dust sampling surveys is to demonstrate that the dust control parameters specified in the ventilation plan are protective. Therefore, MSHA will request that the mine operators adjust elevated airflow levels so that they do not exceed 120% of the values in their plans during MSHA dust sampling [MSHA 2020b].

Section ventilation can be provided in single-split (also called sweep ventilation) or double-split (also called fish-tail or T-split ventilation) configurations as shown in Figure 4.3. In single-split ventilation, intake air is brought in on one side of the section and sweeps across all faces before exiting in the return on the other side of the section. When the continuous miner is operating in the main intake entry, all faces downwind would be in the dusty return air from the miner as shown in Figure 4.3, left. For double-split ventilation, intake air is brought in the center entry or entries and split into two branches. One branch will ventilate the left-side entries while the second branch will ventilate the right-side entries. For mines operating two CMs on the same section (called super sections), double-split ventilation provides an intake airstream to both CMs which prevents the dust generated by one CM from being carried to the second CM operator as shown in Figure 4.3, right.

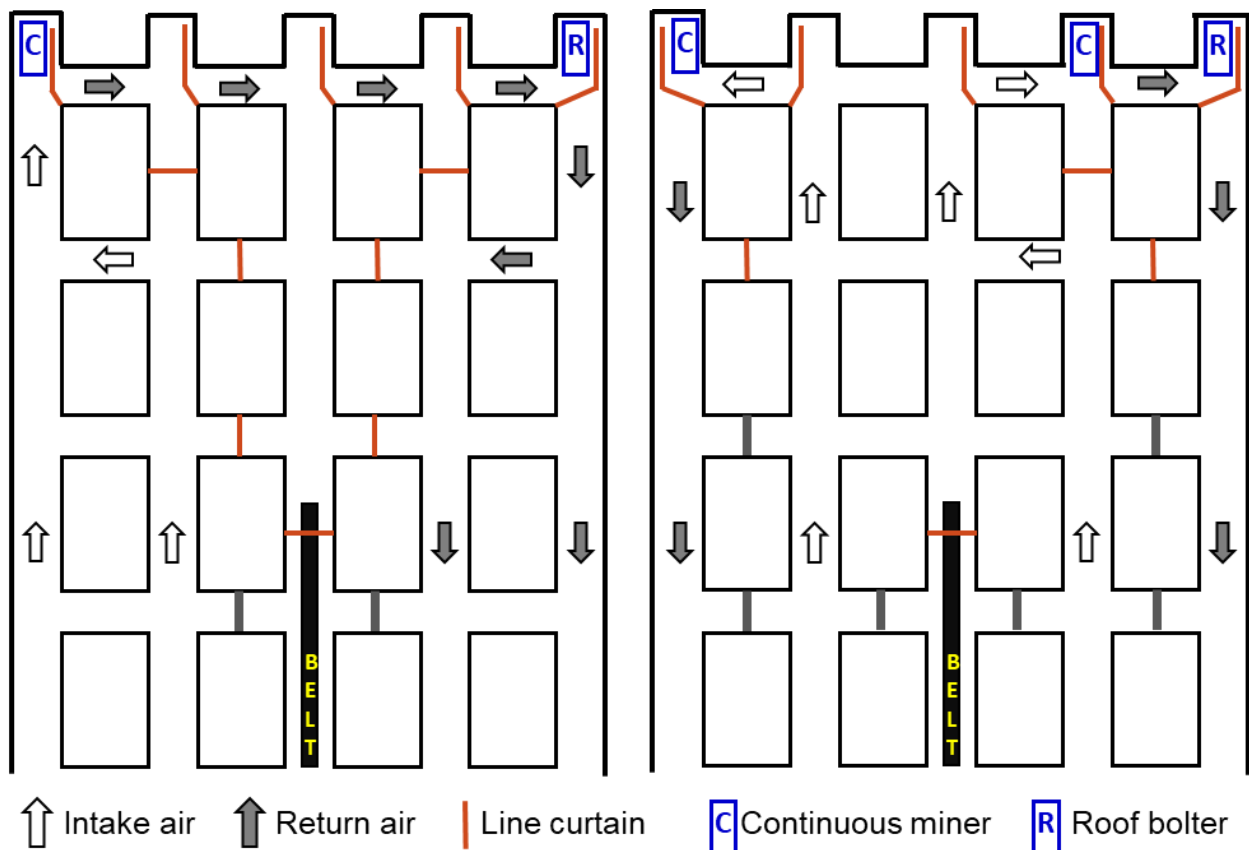

**Figure 4.3. Single-split (left) and double-split (right) face ventilation for continuous mining sections.**



Ventilating air may be directed to the face with either line curtain or tubing when auxiliary fans are used. To demonstrate compliance with the ventilation plan, air quantity measurements must be taken at or near the face end of the line curtain or tubing. If the CM is equipped with a machine-mounted dust collector (flooded-bed scrubber), MSHA regulations [30 CFR 75.325(2)] require that the scrubber fan is off when measuring the face airflow quantity. Mining cannot begin if the minimum air quantity specified in the ventilation plan is not supplied to the face, and adjustments must be made to obtain the required quantity.

Exhausting or blowing face ventilation patterns can be used to supply air to the mining faces. Each of these ventilation types and their impact on respirable dust exposures are discussed later in this chapter.

### Intake Air Dust Control

Beginning on August 1, 2016, as part of its 2014 dust rule, MSHA requires the average concentration of respirable dust in intake air to be maintained at or below  $0.5 \text{ mg/m}^3$  within 200 ft outby the working faces. Maintaining this concentration requires attention from mine operators to address activities that can raise intake air dust levels. Typically, high levels of intake dust are sporadic and result from activities in the intake entries that may take place over the course of a working shift. These activities can include:

- delivery of supplies and/or personnel
- moving equipment in intake entries
- rock dusting
- scoop movement
- construction activities

To eliminate these sources of dust generation, these outby activities should be completed on nonproduction shifts when possible. Wetting the roadway or chemical application as discussed in Chapter 3 may be necessary if dry material on the floor is being disturbed and entrained into the ventilating air.

The belt entry can be used to bring intake air to the working faces but is a potential source of dust generation. Research by the United States Bureau of Mines (USBM) measured the dust level impact of using belt air for face ventilation on continuous mining sections [USBM 1992a]. Controls at the belt head helped maintain low dust levels in the belt entry. Automated sprays were used to suppress dust at the section-to-main belt transfer point. A belt scraper equipped with sprays controlled dust by cleaning the outside surface of the belt after the coal had been transferred to the main belt. These control measures are discussed in more detail in Chapter 3.

Dust measurements show that feeder-breaker operations can contribute an undesirable amount of respirable dust into the mine air, which emphasizes the need for dust controls at this location [USBM 1992a]. Also, another USBM study of outby areas showed that the highest respirable silica dust concentrations were found at the feeder-breaker and averaged nearly  $50 \text{ } \mu\text{g/m}^3$  from the mines that were sampled [USBM 1990a].

The following are some basic controls for reducing dust at the feeder-breaker:

- MSHA recommends using full cone sprays at the feeder-breaker to wet coal and silica dust and hollow cone sprays to knock down airborne dust [Ondrey et al. 1995].

- Dust levels can be decreased by using automated sprays at the feeder-breaker that activate during shuttle car unloading to wet the coal before it enters the breaker.
- Throat sprays on the CM will wet coal when entering the conveyor and lessen dust when transferred to the shuttle car. If sufficient moisture has been added by these sprays, it will help to minimize dust liberation as the shuttle car empties at the feeder-breaker. Redistributing a portion of the water available on the CM may be necessary to ensure that the loaded coal contains sufficient moisture [Ondrey et al. 1995].

### Exhausting Face Ventilation

When exhausting ventilation is used, intake air is delivered to the face in the working entry as illustrated in Figure 4.4. The intake air sweeps the face and the dust-laden air is then drawn behind the return curtain or through exhaust tubing and carried to the return entries. This system allows most of the mining entry to be in intake air, which is beneficial for the respirable dust exposure for all personnel in the face entry. However, research has shown that exhaust face ventilation airflow does not penetrate as deeply into the face as blowing ventilation, particularly as curtain setback distance increases [USBM 1969]. This may be a concern for controlling methane emissions in gassy operations, especially when taking extended cuts of up to 40 feet. The airflow patterns in Figures 4.4 and 4.5 are somewhat exaggerated to emphasize the difference in penetration into the face between exhausting and blowing face ventilation.

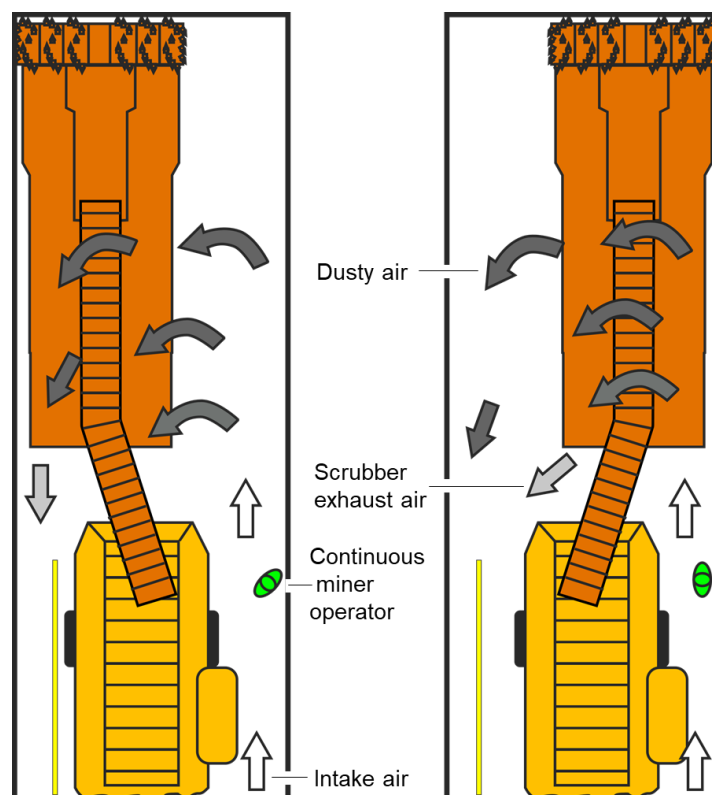

**Figure 4.4. Schematic of exhaust face ventilation system showing desired operator positioning for cuts taken on the left (left) and right (right) side of the entry.**

Exhaust face ventilation allows haulage car operators to remain in intake air while the car is being loaded behind the continuous miner. This ventilation also affords the CM operator more

freedom of movement than a blowing ventilation system, but it is recommended that the operator should be positioned on the off-curtain side of the entry [Schultz and Fields 1999]. This keeps the operator as far away as possible from the dust-laden air that is moving toward the return curtain or tubing. An added safety benefit of the CM operator being on the opposite side of the entry from the curtain is that haulage car operators can more easily see the CM operator as their cars enter the face area. However, good communication between the CM operator and haulage car operators is essential for safe operation, regardless of the face ventilation being used. Also, the CM operator must be aware of the swing range of the loading boom and remain a safe distance away as shown in Figure 4.4, right.

The following practices will help reduce dust exposure on exhausting ventilation sections:

- MSHA regulations require that mean entry air velocity reaching the face must be at least 60 feet per minute (fpm) when using exhaust ventilation systems [30 CFR 75.326]. This velocity will help prevent dust generated at the CM cutting head from rolling back into the entry. A lower mean entry air velocity may be approved by MSHA in the ventilation plan if that velocity is demonstrated to be capable of maintaining methane and respirable dust at required levels.
- The end of the line curtain or tubing should be outby the scrubber discharge to prevent redirecting the scrubber exhaust into the intake air.
- The CM operator should be positioned parallel to or outby the end of the line curtain or tubing. This will reduce exposure to dust-laden return air. [Colinet and Jankowski 1996; Goodman and Listak 1999].
- Scrubber exhaust should be discharged on the return side of the entry and directed toward the return curtain or tubing [Colinet and Jankowski 1996]. If necessary, the CM can be equipped with a crossover duct to carry the exhaust to the opposite side of the miner.
- The end of the exhaust curtain or tubing when not using a scrubber must be kept within 10 ft of the face or an alternative distance if approved by MSHA in the ventilation plan [30 CFR 75.330]. The setback distance must be capable of providing ventilating air that effectively controls methane and respirable dust levels.

## Blowing Face Ventilation

When blowing ventilation is used, intake air is delivered to the face by discharging it from behind line curtain as shown in Figure 4.5 or through tubing. The clean air is blown toward the face and sweeps dust-laden air into the return entry, which is the widest portion of the working entry. This system allows the CM operator to reduce dust exposure by being positioned in the intake air at the inby end of the blowing curtain or tubing [Goodman and Listak 1999; Schultz et al. 2010]. However, this limits the operator's movement to this location. Otherwise, the operator will be located in the main part of the entry, which is in return air and likely increasing dust exposure. If curtain is used, good communication with haulage car operators is essential because the CM operator may not be clearly visible behind the line curtain. As previously mentioned, the CM operator must be aware of the loading boom and remain a safe distance away from the boom as shown in Figure 4.5, right. If the curtain setback cannot be extended far enough away from the CM boom for the operator to safely operate, the operator may have to reposition to the left side of the entry. Unfortunately, this is in return air and may increase dust exposure during this portion of the cut.

For an equivalent face air quantity, blowing ventilation will result in a higher intake air velocity being discharged from behind the line curtain or tubing, when compared to the mean entry air velocity seen with exhaust ventilation. This higher airstream velocity allows for deeper penetration into the face area by the intake air, providing improved mixing and dilution of methane. However, intake air quantity must be equal to or above the measured scrubber airflow provided to the face to prevent recirculation of dust-laden face air, which could result in increased dust exposure for the CM operator [Schultz et al. 2010]. Face airflow measurements must be taken with the scrubber off to obtain accurate intake air readings.

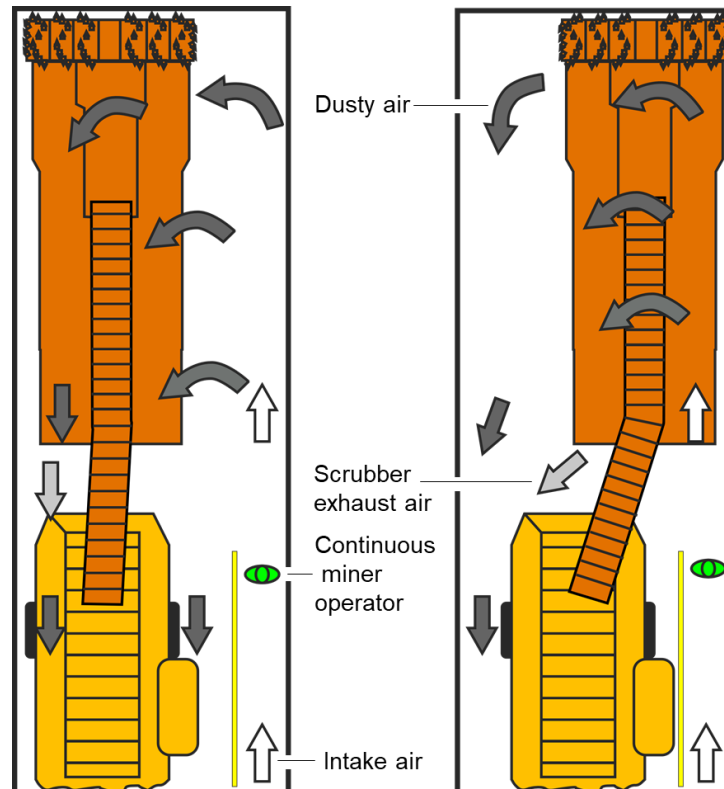

**Figure 4.5. Schematic of blowing face ventilation system showing desired operator positioning for cuts taken on the left (left) and right (right) side of the entry.**

Unfortunately, from a dust control perspective, blowing ventilation positions shuttle car operators in return air, resulting in elevated dust exposures when compared to shuttle car operators working in exhaust ventilation. NIOSH research has shown that shuttle car operator exposures when loading at the CM with blowing ventilation were on average  $0.85 \text{ mg/m}^3$  higher than those observed with exhaust ventilation [Beck et al. 2016] and nearly  $2.0 \text{ mg/m}^3$  higher at some mines [NIOSH 2011].

The following best practices can be used to reduce dust exposure on blowing ventilation sections:

- The CM operator should not routinely be positioned on the return side of the ventilation curtain or tubing during active mining. If the operator is routinely on the return side near the curtain or tubing, a portion of the intake air can be bled over the operator to provide a fresh

airstream. As long as methane remains controlled, the line brattice can be partially opened or a diffuser section of tubing can be installed to bleed fresh air to the operator.

- Using shuttle cars with the cabs located on the intake side of the entry can lead to lower exposures than for cars with the cab on the off-curtain side [Schultz and Fields 1999].
- When it is necessary for the operator to move from the optimum clean air position, the operator should allow the dust-laden air to clear the entry and stop the scrubber (if present) before moving across the entry.
- When aligning the CM to square a face, the operator should position the machine without cleaning/cutting and then return to the end of the curtain before cleaning/cutting resumes. This reduces the potential for dust exposure.
- Scrubber discharge must be on the opposite side of the entry from the intake line brattice or tubing to allow scrubber exhaust to be discharged directly into return air and not interfere with the intake airstream. The scrubber discharge airflow should not liberate dust by being directed at or blowing over a dry mine floor. If dust is being entrained, the mine floor can be sprayed to increase moisture content.
- When using a scrubber, MSHA has historically recommended that the air quantity provided to the face should be equal to the measured air capacity of the scrubber with an upper limit of 20% or 1,000 cfm over the scrubber capacity [Schultz et al. 2010]. More recent controlled laboratory testing has shown that a face airflow of 5,000 cfm above the scrubber airflow resulted in reduced dust levels at the shuttle car and return sampling locations without increasing CM operator dust levels [Klima et al. 2019].
- When using a scrubber, it can continue to be operated for 10–20 seconds after all cutting/loading has been completed to capture any remaining airborne dust in the face. This can prevent or minimize this dust from rolling back into the entry.

## Crosscut Breakthroughs

Extracting crosscuts is a necessary part of the mining cycle but presents challenges from a dust control perspective. When initiating a crosscut, the severe angle of the CM and positioning of the haulage car behind the miner for loading can result in the miner operator needing to reposition from the desired location from a dust control perspective. Also, it may be difficult to initially establish face ventilation that prevents dust from rolling back toward the operator. To illustrate, a summary of NIOSH research in continuous mining operations showed that the respirable dust exposure for the CM operator was nearly  $1.0 \text{ mg/m}^3$  higher in crosscuts when compared to cuts in the headings [Beck et al. 2016].

When completing the crosscut and breaking through into the adjoining entry, the direction of extracting the crosscut can have a substantial impact on the dust exposure of the CM and shuttle car operators. If the breakthrough occurs into the section ventilation as shown in Figure 4.6, left, the intake air short-circuits and carries dust directly toward the equipment operators, increasing their exposure (Figure 4.6, right). If the crosscut breakthrough occurs with the section ventilation, dust-laden air is quickly carried away from the face personnel. Respirable dust concentration in crosscuts breaking into the face ventilation were over  $0.6 \text{ mg/m}^3$  higher [Beck et al. 2016].

For the above reasons, all crosscut breakthroughs should be made with the section ventilation. When not possible, the last portion of the box cut that would result in a breakthrough should not be fully completed, but a small portion of coal can be left in the box cut side. The CM should

then be repositioned into the slab cut, and the slab cut should be completed with a breakthrough at the end of the cut. The short portion of the box cut can then be removed to complete the full breakthrough. This reduces the time that the desired face ventilation pattern is disrupted, thus lowering the operator's dust exposure.

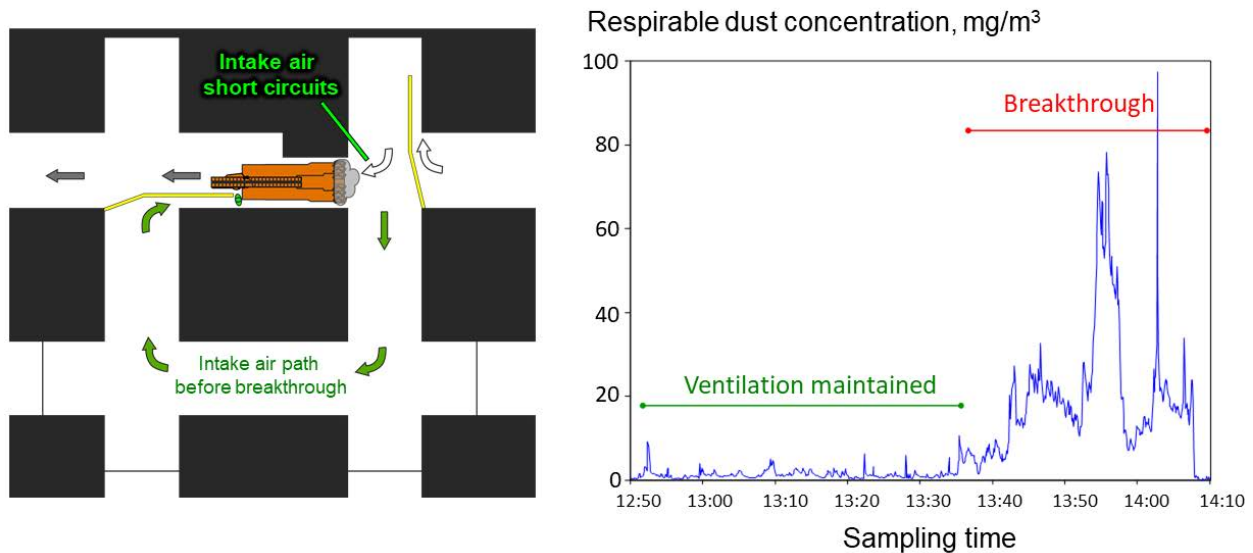

**Figure 4.6. Illustration and line graph demonstrating how crosscut breakthrough into ventilating air short-circuits intake air (left) and results in increased CM operator dust levels (right).**

## Continuous Miner Dust Control

Cutting by the CM represents the greatest source of dust generation on CM sections. Not only is the dust generation a concern for the CM operator, but dust generated by the CM can expose workers downwind of the miner. Therefore, controls should be implemented to reduce dust generation by the CM to as low an amount as possible. The following discussion represents methods for achieving this goal.

### Efficient Cutting

If the minimum quantity of respirable dust is generated during mining operations, then a lesser quantity of respirable dust must be controlled through other technologies. To minimize the amount of respirable dust generated, efficient cutting by the CM should be a primary goal.

### Cutting Bits

Cutting bit selection can greatly affect respirable dust concentrations generated during cutting. A study showed that CM bits designed with large carbide inserts and smooth transitions between the carbide and steel shank as shown in Figure 4.7, left, typically produce less dust [Organiscak et al. 1996]. Lab studies from this research showed that significantly worn conical bits without their carbide tips consume more energy and produce more dust, with higher fractions of respirable dust. After the carbide tip is worn off, the steel body wears even faster. Figure 4.7, right, shows a severely worn bit that NIOSH researchers found during a dust survey. Obviously, this bit was grinding against the cutting surface for some time and should have been replaced as soon as the carbide insert was worn down. Routine inspection of bits with the



replacement of dull, broken, or missing bits improves cutting efficiency and helps to minimize dust generation.

Past research has also shown that increased bit penetration leads to reduced respirable dust generation [Roepke 1984]. Bit sharpness, bit spacing, cutting drum revolutions per minute (rpm), and CM advance rate all impact bit penetration and can be modified to optimize penetration and reduce dust generation.

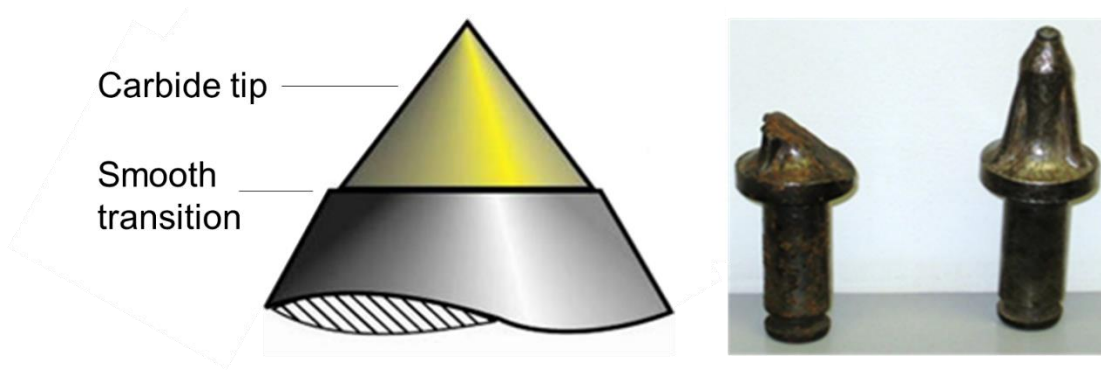
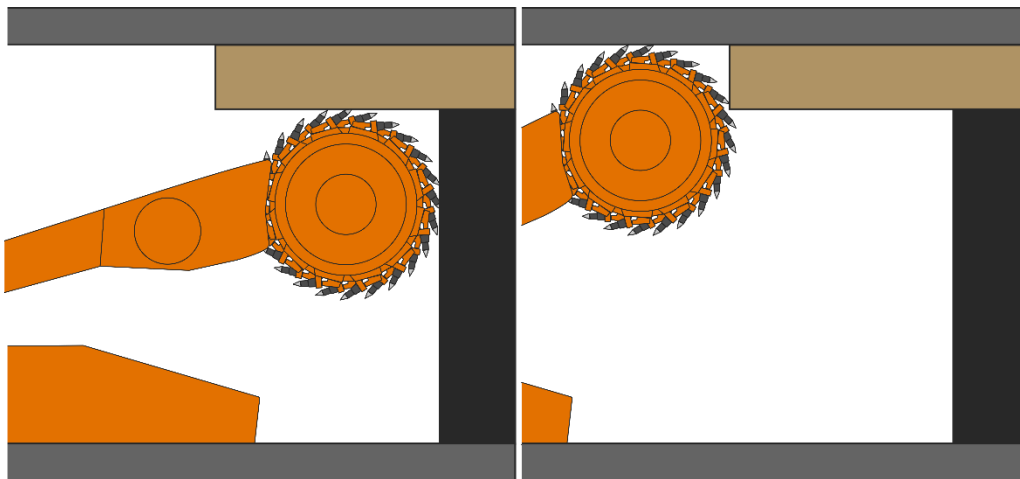

Photo by NIOSH

**Figure 4.7. Illustration showing proper bit design (left), which can lower dust generation. Photo comparing a severely worn and new bit (right).**

#### *Modified Cutting Method*

If roof rock must be cut (typically for equipment clearance), it can be beneficial to cut the coal beneath the rock for several feet and then back the CM up to cut the remaining rock, as illustrated in Figure 4.8. This cutting method leaves the rock in place until it can be break out to a free, unconfined space, which creates less respirable dust [USBM 1985]. If the rock contains quartz, this method will also reduce the amount of quartz dust generated.



**Figure 4.8. Illustration of how respirable dust generation is reduced by under-cutting roof rock (left) and then backing up to extract rock (right).**

## Water Sprays

Most CMs operate with water sprays located at multiple locations on the machine in order to achieve the desired dust control. These spray locations can include the cutting boom, the loading pan, the sides of the miner (side and blocking sprays), the conveyor throat, and in the cutting drum. As noted in Chapter 3, water sprays can suppress dust by wetting, redirecting dust, or removing dust from the air. The purpose of using sprays at each of these locations is discussed below, while Figure 4.9 illustrates these spray locations.

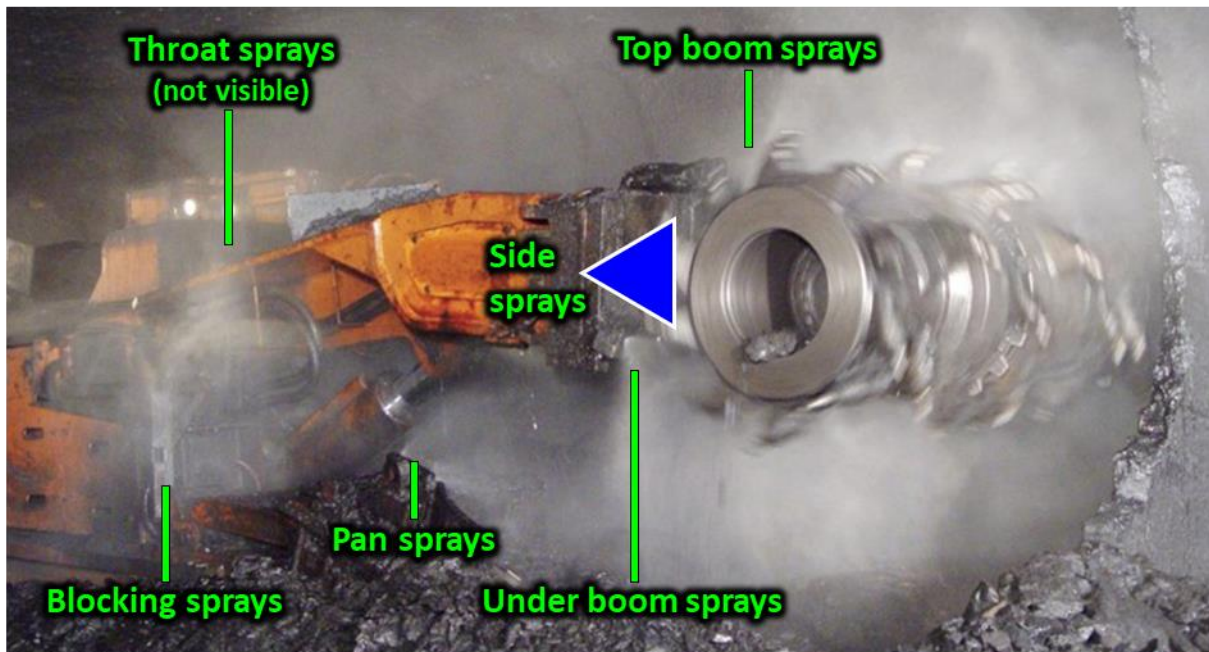

Photo by Business Media MAGS

**Figure 4.9. Common spray locations on continuous miners. Blue triangle indicates location and operational direction of side sprays (which were not present in the original photo).**

## Cutting Boom Sprays

For dust control, the sprays on top of the cutting boom are typically oriented directly at the bits on top of the cutting drum. These sprays provide bit lubrication, cooling, and dust control by wetting coal as it is being cut. A directional spray system can also be used on CMs with sprays mounted across the top of the cutting boom and will be discussed later in this chapter. It is common to mount a number of spray manifolds across the top of the boom directly behind the cutting drum to provide spray coverage and uniform wetting across the entire drum. One concern with the use of these sprays is that if the spray location or operating pressure is incorrect, the sprays can increase dust liberation by forcing dust to roll back into the mining entry. Therefore, it is recommended that the sprays are located as close to the cutting head as possible and operated at less than 100 pounds per square inch (psi) to minimize rollback. Early research indicated that flat fan sprays with horizontal spray patterns were the recommended spray type to direct water to the cutting bits while minimizing rollback by limiting water droplet impact with the mine roof [Jayaraman et al. 1984]. More recent research conducted with a flooded-bed scrubber operating in exhaust ventilation indicated that hollow cone sprays can be effectively operated on the top of



the cutting boom and that an operating pressure of 80 psi was more beneficial than 160 psi [Organiscak and Beck 2010].

Early research on spray types and locations for use on continuous miners identified the dust reduction benefit of locating sprays under the cutting boom [USBM 1976]. Under-boom sprays can provide two functions. They can be directed at the bottom of the cutting drum, as shown in Figure 4.9, to provide wetting of the cut coal as it is discharged from the bottom of the drum. Similar nozzles as mentioned for the top of the cutting boom can be used under the boom at an operating pressure of 60 psi or less, so as not to force dust-laden air out from under the boom. Sprays can also be mounted under the boom and be directed at the gathering arms and loading pan to provide wetting of the broken material as it is gathered and pulled into the conveyor. For these sprays, water quantity delivery for wetting is the goal, and larger orifice sprays at low operating pressures are the most appropriate choice.

Flat fan sprays can be mounted with a vertical spray pattern on the sides of the cutting boom in the position represented by the blue triangle added to the photo in Figure 4.9. These sprays are angled slightly out from the sides of the machine and help confine generated dust near the cutting head while wetting the bits on the ends of the drums. Importantly, these sprays should not be angled so greatly that the spray patterns impact the rib and cause rollback.

### *Gathering Pan Sprays*

Sprays can be mounted on the sides of the gathering pan and directed toward the front center of the gathering pan to provide additional wetting of the cut material as it is being loaded. For this purpose, full cone nozzles should be used at an operating pressure of 60 psi or less. However, sprays located on the gathering pan can also be used to induce air movement toward the return side of the entry. This is particularly important for CMs that are operating without a flooded-bed scrubber, where the face airflow is primarily responsible for controlling respirable dust. In this case, a spray manifold should be mounted on the intake side of the CM and oriented toward the return side of the entry. Hollow cone sprays operated at 175 psi were shown to reduce respirable dust levels at the operator location [USBM 1989].

### *Conveyor Throat Sprays*

Sprays should be located in the conveyor throat of the CM to wet the mined product as it travels up the conveyor for loading into the shuttle car [USBM 1985]. The goal of adding moisture at this location is to minimize dust liberation as the coal discharges from the loading boom of the CM and lands in the shuttle car. If the coal is not sufficiently wet, dust will be liberated along the length of the CM conveyor and at the shuttle car. Both of these dust sources are closer to the miner operator than dust being generated at the face. In addition, added moisture retained in the mined product will help reduce dust liberation when the shuttle car unloads at the feeder-breaker. Therefore, full cone sprays with larger orifices and operating at low pressures are an appropriate choice.

### *Blocking Sprays*

Spray manifolds mounted on the sides of CMs outby the flooded-bed scrubber inlets have been shown to improve dust control when used with blowing face ventilation. In a NIOSH study [Goodman 2000], flat fan sprays mounted with vertical spray patterns were mounted roughly 2 ft outby the scrubber inlets. The sprays were oriented approximately 30 degrees out from the

machine body toward the rib and operated at 50 psi. Test results in a full-scale dust gallery and then at a mining operation indicated that dust levels at the rear of the CM were lower. It appeared that the blocking sprays assisted in keeping the dust generated by the cutting head in the face area longer, allowing for greater capture by the flooded-bed scrubber.

### *Wet Head Sprays*

As noted in Chapter 3, water sprays on longwall shearer cutting drums are located in front of or behind the cutting bits to suppress dust at the point of cutting. Sprays located behind the bit were also shown to reduce the likelihood of frictional ignitions. Over 30 years ago, several attempts to implement sprays on the cutting heads of CMs failed due to the lack of dependable water seals for the design of the cutting head on the CM. More recently, improved water seals have been developed that resulted in water sprays being placed behind the cutting bits on CMs, as shown in Figure 4.10, for improved frictional ignition control and potentially improved dust control.



Photo by Joy Global Underground Mining

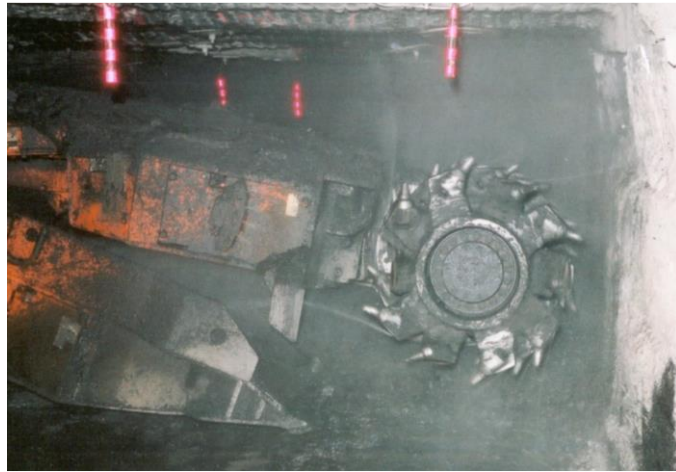
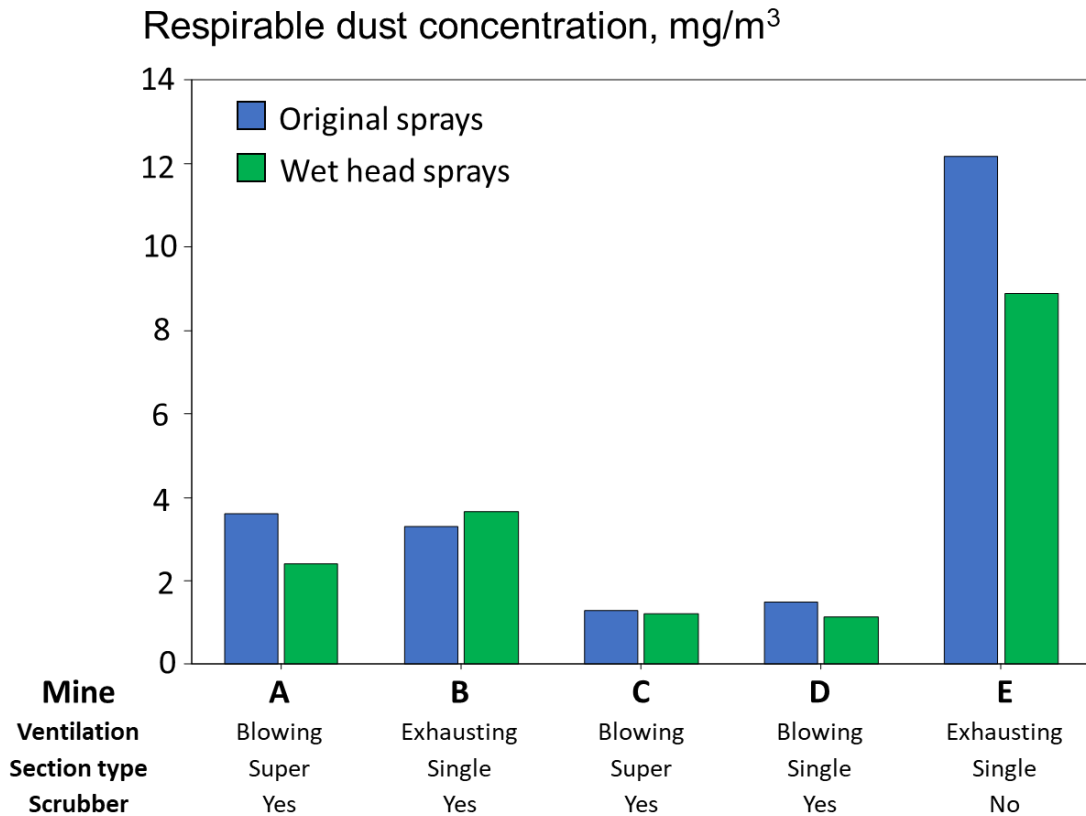

Photo by NIOSH

**Figure 4.10. Wet head spray located behind cutting bit (left) and system operating on a continuous miner underground.**

NIOSH conducted surveys at five mines to evaluate the dust control potential of the wet head spray system when compared to the existing external spray system being used by each mine (labeled “Original sprays” in Figure 4.11) prior to the time of installing the wet head [Listak et al. 2010]. Key operating conditions at these mines and results for return dust levels measured during these surveys are provided in Figure 4.11. At Mines A and E, reductions of 33% and 27%, respectively, were found in return dust levels when the wet head spray system was operated. At the other three mines, minimal reductions or increases in return dust levels were found with the wet head sprays operating. Consequently, operation of the wet head sprays system did not produce consistent dust control performance across these mines.



**Figure 4.11. Comparing return dust concentrations with wet head spray systems to original spray systems used at five mines, with key operating conditions listed for each mine.**

Another observation from these surveys shows that at the four mines where the CMs were equipped with flooded-bed scrubbers, operation of the scrubbers appeared to be the dominant dust control technology. Respirable dust levels in the returns at all four mines using a scrubber were substantially lower than at the mine without a scrubber, regardless of the spray system being used.

### *Spray Fan Directional Sprays*

As discussed in Chapter 3, water sprays can be used to direct airflow, and a successful directional spray system has routinely been used on longwall shearers to reduce the dust exposure of shearer operators. A directional spray system for a CM (also known as the spray fan system) was developed for use with exhaust face ventilation and no scrubber to help prevent the buildup of methane gas at the face. This system places sprays in a defined pattern on the CM [USBM 1983a] to assist in moving air up the intake side of the entry, sweeping air across the face, and directing air toward the return curtain or tubing. Hollow cone sprays are used in this system to take advantage of their air moving capability. Since the goal of this system is to move air, water pressures of 150 psi or greater are more effective. Initial testing indicated that up to 70% of the intake air could reach within 1 ft of the face when using the spray fan system [Kissell et al. 1979].

This spray system is designed to promote turbulence, mixing, and dilution of methane by the intake air. However, from a dust control perspective, turbulence created by high-pressure sprays

can result in dust rollback toward the CM operator. NIOSH laboratory testing evaluated the spray fan system while simulating a deep cut face at two operating pressures (70 and 190 psi), two face airflow quantities, and two curtain setback distances [Goodman and Pollock 2004]. Results showed higher CM operator dust levels at the higher operating pressure for all test conditions. At shuttle car operator positions and in the return, the higher operating pressure resulted in increases or decreases in dust levels depending upon the other combinations of parameters being tested. As a result, the spray fan system should be viewed with caution and evaluated at the specific mine conditions when dust control is the primary goal.

### Flooded-Bed Scrubbers

Flooded-bed scrubbers are fan-powered dust collectors installed on CMs to capture dust-laden air at the cutting face. This air is drawn into inlets mounted close to the cutting head and through steel ductwork toward the back of the CM, where a multi-layer mesh filter panel is being wetted by a water spray or sprays. As the dust particles and water droplets impact the filter mesh and work their way through the layers, the dust particles become encapsulated in the water droplets. After exiting the filter panel, these dust-laden water droplets encounter a wave-blade mist eliminator which causes the airstream to make numerous turns through the unit. The momentum of the dust-laden water droplets causes them to strike the mist eliminator blades and be removed from the airstream. The relatively clean, dry air is then discharged by the fan back into the mine atmosphere. Figure 4.12 illustrates the components and layout of a common flooded-bed scrubber design.

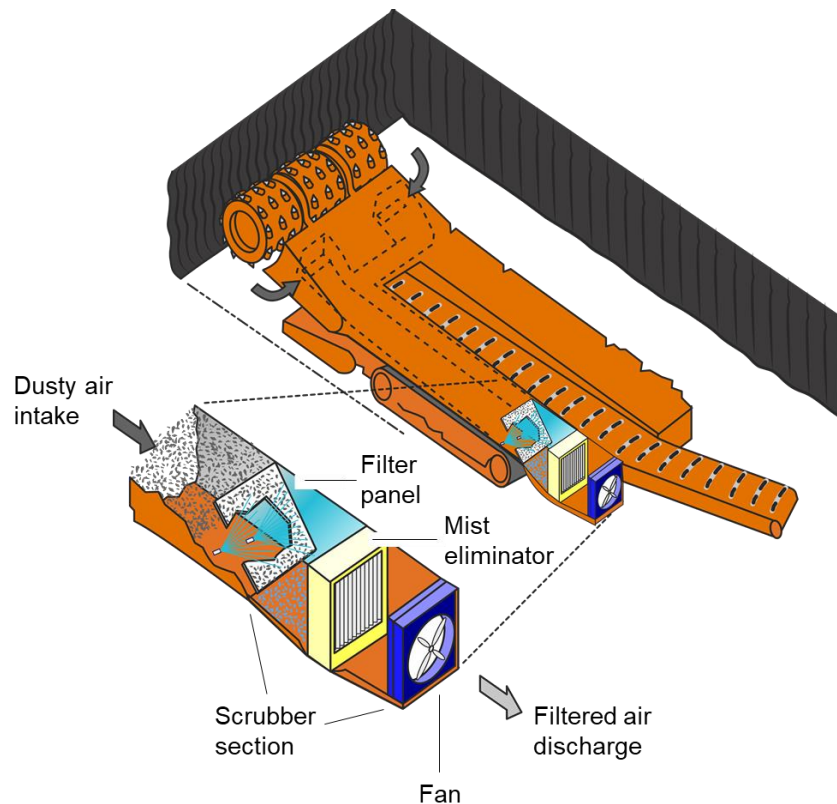

**Figure 4.12. Components and layout of a flooded-bed scrubber.**

The initial flooded-bed scrubber design was patented in 1983 [Campbell et al. 1983] but not extensively adopted by the mining industry. However, the development of radio remote control for CMs led to the potential for extracting extended cuts greater than 20 ft in depth. With remote control, the CM operator can remain under supported roof while the CM advances up to 40 ft in cut depth. Extended cuts reduce the number of face changes required by the CM, which can lead to higher production and potentially fewer injuries that occur during CM moves. Therefore, most U.S. continuous mining operations prefer to take extended cuts when mining conditions permit.

The use of extended cuts must be approved by MSHA after assessing the competence of the roof and the mine's ability to control methane and respirable dust to regulated levels. Operation of the scrubber aids in increasing the quantity of ventilating air reaching the face for methane control and also removes a large percentage of respirable dust. Consequently, the flooded-bed scrubber is a key component in receiving extended cut approval from MSHA for many mining operations. This has led to widespread use of scrubbers, and it is estimated that over 90% of CMs now in use in the United States are equipped with scrubbers [Defibaugh 2018].

### *Dust Control Effectiveness*

The overall dust reduction achieved with flooded-bed scrubbers is determined by the capture efficiency and collection efficiency [Colinet and Jankowski 2000]. The capture efficiency is the quantity of face ventilation air that is drawn into or “captured” by the scrubber. This is determined from the air-moving capacity of the scrubber and the quantity of ventilating air supplied to the face. For example, if the scrubber has a capacity of 7,500 cfm and 8,000 cfm of air is supplied to the face, the scrubber will ideally capture nearly 94% of the ventilating air. As a result, increasing the air-moving capacity of flooded-bed scrubbers can be beneficial. Maximum scrubber airflow capacity has increased to 20,000 cfm [Defibaugh 2020].

The collection efficiency represents the percentage of respirable dust entering the scrubber that is removed by the scrubber before the air is discharged back into the mine atmosphere. For example, if the dust concentration of the air entering the scrubber is 10 mg/m<sup>3</sup> and the concentration of the air discharged by the scrubber is 1 mg/m<sup>3</sup>, the collection efficiency would be 90%.

Research has been conducted to evaluate the respirable dust collection efficiency of flooded-bed scrubbers while implementing supplemental controls within the scrubber, using different filter media, and using different filter densities [USBM 1990b; Colinet and Jankowski 2000]. The supplemental controls (adding surfactant or oil emulsion to the scrubber spray water or adding atomizing or fogging sprays as preconditioning sprays upwind of the normal sprays) resulted in minimal improvement in dust collection and, as a result, were never adopted. Different filter materials (bottle brush and synthetic materials) showed potential dust collection benefits but their use has waned (bottle brush) or was never implemented on a production basis (synthetic material) after initial underground testing [McClelland et al. 1991].

At the initiation of the USBM-cited research effort, the standard filter panel being used in scrubbers contained 40 layers of stainless steel mesh in a flat-panel design. Figure 4.13, left, shows this panel along with an 18-inch ruler for scale and a sample of the stainless steel filter material removed from a panel. As expected, laboratory testing indicated that the denser the filter the higher the collection efficiency, with 30-, 40-, and 80-layer flat panels removing 93%, 96%, and 99% of respirable dust, respectively [USBM 1990b]. Unfortunately, as the filter density



increases, the pressure drop across the filter also increases, resulting in reduced scrubber airflow [Colinet and Jankowski 2000]. At approximately 5,000 cfm scrubber airflow, the pressure drop for the 30-, 40-, and 80-layer filters was 2.7, 4.1, and 8.0 inches of water column (in. wc), respectively. If the pressure drop increase is severe enough, fan stall can occur.

For particles above 5 micrometers ( $\mu\text{m}$ ) in aerodynamic size as collected with impactors during the USBM tests, the collection efficiency for the different filters and test conditions were between 97.5% and 99.7%. However, as the particle size decreased below 5  $\mu\text{m}$ , the collection efficiency decreased for all filters and test conditions. In addition, the difference in collection efficiency between the filters and other test conditions became greater, with collection efficiencies ranging from 72% to 95% for 1.1–2.1  $\mu\text{m}$  particles.

Filter clogging from particles pulled into the scrubber also increases pressure drop and reduces airflow through the scrubber as a cut progresses. In order to create greater filter surface area, pleated filters have become the standard design currently being used. Pleated filters containing 30, 20, and 10 layers of stainless steel mesh were readily available at one time and used in mines. Figure 4.13, center and right, shows 10- and 30-layer pleated filter panels, respectively, that are being backlit. The greater amount of light visually passing through the 10-layer filter panel illustrates the substantial difference in density for these two filters.



Photos by NIOSH

**Figure 4.13. Forty-layer flat filter panel with mesh material shown (left). Ten-layer (center) and 30-layer (right) pleated panels with backlighting to show relative difference in filter density.**

The respirable dust collection efficiency and measured scrubber airflow for 30-, 20-, and 10-layer filters are shown in Figure 4.14 [Colinet and Jankowski 2000]. In this testing, a variable speed fan was adjusted so that approximately 7,900 cfm was flowing through the scrubber with the 20-layer filter installed. Without adjusting the fan, the 30- and 10-layer filters were then inserted and the airflow was measured. The inverse relationship between respirable dust collection efficiency and scrubber airflow for changes in filter density is clearly shown in this graph. The dust collection efficiency dropped from 93% for the 30-layer filter to 74% for the 10-layer filter, but airflow increased from 6,900 cfm for the 30-layer filter to over 8,200 cfm with the 10-layer filter. The leading CM scrubber manufacturer indicates that it no longer supplies 10-layer filters and only supplies 20- or 30-layer filter panels [Defibaugh 2021].

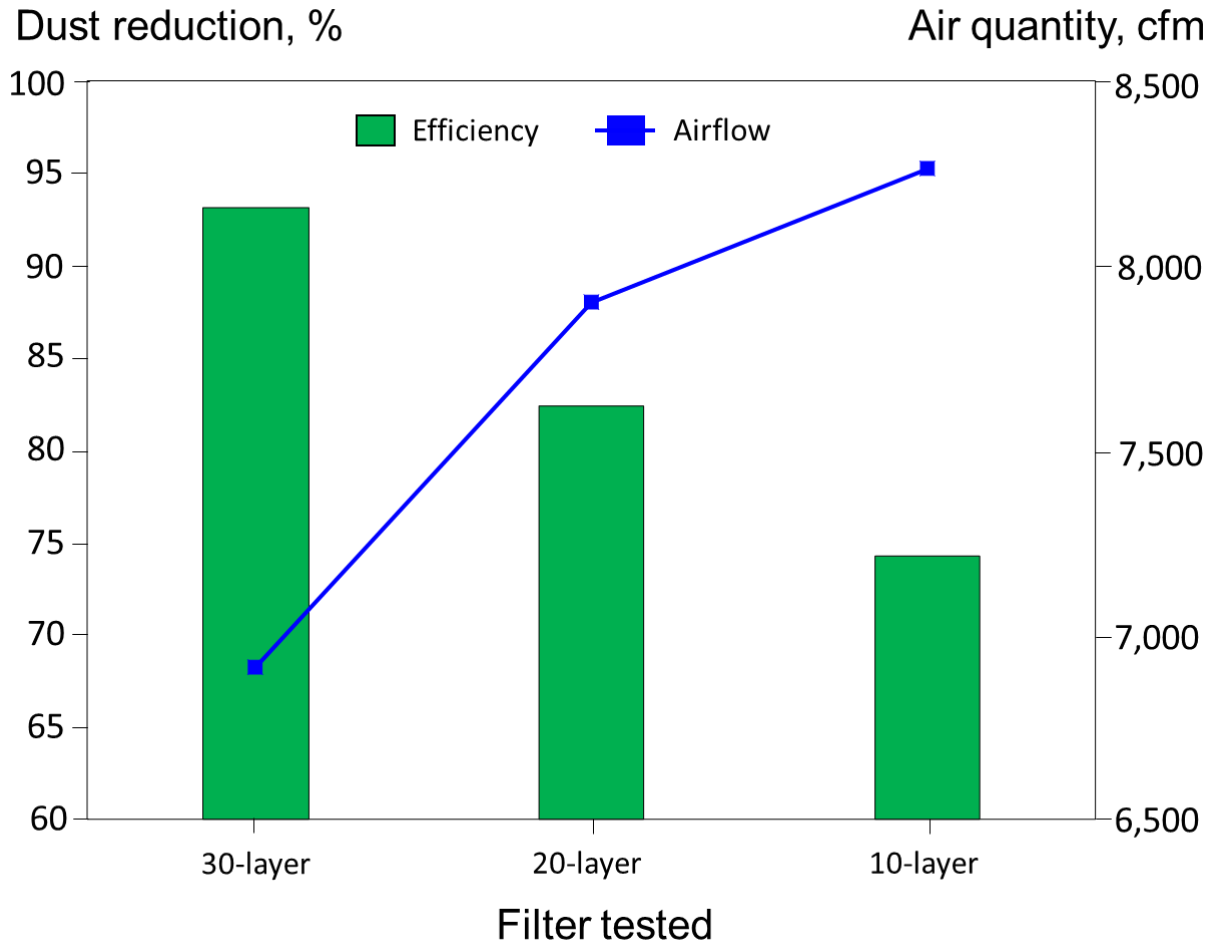

**Figure 4.14. Respirable dust reduction and scrubber airflow with different-density filters.**

Optimum flooded-bed scrubber performance would be achieved if all of the dust-laden air at the cutting face is drawn into the scrubber and a high percentage (> 90%) of the respirable dust is removed from this air [NIOSH 1997]. Full-scale laboratory and mine-site testing have shown that operation of the scrubber can reduce dust levels in the return by 80% to 90% [Colinet and Jankowski 1996; NIOSH 2013]. Therefore, it is very important to monitor and maintain scrubber airflow at maximum levels.

### *Scrubber Airflow Measurement*

Full pitot tube traverses must be conducted periodically by the mine operator (frequency may be included in the ventilation plan) to quantify the airflow through the scrubber. MSHA requires that approximately 16 data points but not less than 14 be collected to determine the average scrubber velocity [MSHA 2020b]. Measurement ports are created by drilling holes in the scrubber ductwork that are equally spaced, while being less than six inches from the ductwork sides and each other. The pitot tube is inserted in each of these ports and a minimum of four velocity pressure readings are taken from each port at pre-determined depths within the scrubber ductwork. The velocity pressure readings are converted to velocity readings and then averaged to obtain the average air velocity within the scrubber. This average velocity is

multiplied by the internal area of the scrubber to obtain the scrubber airflow volume. A detailed discussion of determining scrubber airflow with a full pitot tube traverse is available on the MSHA website [MSHA 2020c].

MSHA inspectors are required to conduct a full pitot tube traverse on each scrubber during each respirable dust survey [MSHA 2020b]. If the measured air volume does not meet the minimum quantity stated in the ventilation plan, scrubber maintenance must be completed to achieve the minimum quantity before mining can begin as specified in 30 CFR Part 75.362(a)2.

The inspector can use the full traverse data to establish a centerline correlation measurement, which can be used during non-measurement inspections of the scrubber system to determine if the scrubber is being maintained. The mine operator can also submit a centerline correlation in the ventilation plan for MSHA approval. If approved, the mine operator can use the centerline correlation on a cut-to-cut basis instead of a full traverse to determine if the scrubber airflow is suitable. Ideally, a centerline hole is available to obtain the centerline velocity measurement. However, if there are an even number of ports, centerline velocity readings from the two center ports are averaged to determine the centerline velocity. A correlation factor is then calculated by dividing the full traverse average air velocity by the centerline velocity. The correlation factor is then used in the equation below to calculate the scrubber volumetric airflow.

$$\text{Scrubber airflow (cfm)} = \text{centerline velocity (fpm)} \times \text{correlation factor} \times \text{scrubber area (ft}^2\text{)}$$

### *Scrubber Maintenance*

Scrubbers have been shown to be one of the most effective respirable dust controls available to mine operators. Consequently, maintaining performance of the scrubber is a critical component of controlling respirable dust levels. However, it should be noted that scrubber exhaust air can contain dust levels that approach or exceed the current respirable dust standard, as shown for mines A-D in Figure 4.11.

Scrubbers can lose as much as one-third of their airflow after just one cut [Schultz and Fields 1999; NIOSH 2011; NIOSH 2013], so maintenance requirements are defined in the ventilation plan. The most common cause of airflow loss is filter panel clogging, which requires the filter panel to be removed for cleaning or replacement. Water is used to wash down the filter panel to remove particles that are lodged in the filter mesh as shown in Figure 4.15, left. Some mines have multiple filter panels and simply swap one panel for another after a cut has been completed. This can provide time for panels to dry between use, which may allow additional material to be removed by tapping the filter panel.

The scrubber inlets, ductwork, mist eliminator (demister), and sump also need to be inspected and cleaned on a periodic basis. Larger pieces of coal and rock may be pulled into the scrubber inlets and ductwork before settling out of the airstream. Material can become trapped in the mist eliminator and buildup can occur in the sump. A water hose can be used to clean these components, with Figure 4.15, right, showing a mist eliminator being washed down.





Photos by NIOSH

**Figure 4.15. Cleaning scrubber filter panel (left) and mist eliminator (right) with a water spray.**

It is also very important that the spray nozzles in the ductwork be checked to ensure they are not plugged and are wetting the entire filter panel. If the filter panel is not completely wetted by the sprays, respirable dust may pass through the screen to be discharged back into the ambient air. Alternatively, particles may build up on the screen, increasing pressure drop and lowering airflow through the scrubber. Full cone nozzles are often used to provide complete wetting of the filter.

The specific conditions at each mine (e.g., cut depth, mining height, quantity of rock cut) will dictate the frequency of maintenance needed to ensure the scrubber is removing as much respirable dust as possible.

### *Redirected Scrubber Discharge*

When air is recirculated at the face, MSHA has concerns over the potential for methane to build up to unsafe levels. However, a few sections with low methane emissions were granted approval by MSHA to redirect all or a portion of the scrubber exhaust toward the mining face. The redirected airflow could help compensate for low mean entry air velocity, with the goal of reducing dust rollback from the face. NIOSH completed limited testing of scrubber redirection at two mines [Organiscak and Beck 2013]. Several locations in the face area were sampled for respirable dust and mixed results were observed, with some dust levels increasing and others decreasing.

NIOSH also conducted controlled laboratory tests to evaluate the effect of redirecting scrubber exhaust air to the face. One test condition had the exhaust air split with equal portions directed up each side of the CM, while the second test condition had 15% of the scrubber discharge directed up the off-curtain side of the CM [Organiscak and Beck 2013]. From a dust control viewpoint, less than desired results were found when redirecting the scrubber exhaust toward the face.

## Wetting Agents

Coal is hydrophobic and it is not uncommon to see coal dust floating on top of puddled water in underground mines, similar to that shown in the left beaker in Figure 4.16, left. The goal of adding a wetting agent to spray water is to reduce the surface tension of the water to promote improved wetting of the coal as shown in the right beaker in Figure 4.16, left, and more effective airborne dust capture. Through the years, multiple wetting agent tests have been performed in coal mining with mixed results. Some studies have shown negligible dust control improvements [Chander et al. 1991; Tessum and Raynor 2017]; others have shown improved dust capture around 25% [Kost et al. 1980]; and others have shown a 40% improvement at one mine but inconclusive results at a second mine [USBM 1996]. In addition, multiple laboratory techniques (e.g., zeta potential, capillary rise, coal dust sink tests) have been attempted to better match a wetting agent to an individual coal seam, with inconsistent success [Kost et al. 1980; USBM 1983b]. A general finding across these studies and others is that increasing the wetting agent concentration improved wetting, at least up to a certain point [Tien and Kim 1997].

More recently, NIOSH conducted testing in an enclosed dust chamber to evaluate the impact on airborne respirable coal dust capture when adding three different wetting agents to the spray water [Organiscak 2013] at two operating pressures. As shown in Figure 4.16, right, the addition of the different wetting agents resulted in less than 2% improvement in airborne dust capture. This graph shows that slightly larger improvements were obtained by simply increasing the water pressure. However, these tests did not evaluate the potential dust reduction that may result from improved wetting of the mined product by the wetting agents.

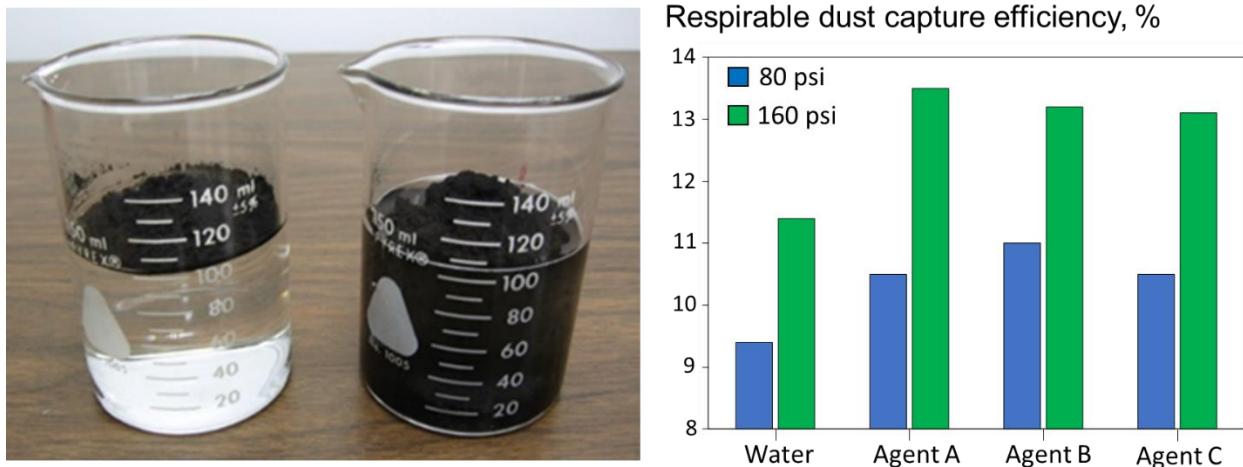

Photo by NIOSH

**Figure 4.16. Hydrophobic coal floating on water and sinking with the addition of a wetting agent (left) and a bar chart representing changes in airborne dust capture with wetting agents (right).**

The addition of a wetting agent exhibits some potential for improving respirable dust control, but studies have shown that the greatest potential results from matching a specific agent with a specific coal. Another factor influencing performance is the properties of the individual mine water, including pH levels [Feldstein 1981]. Unfortunately, laboratory tests have not been consistently reliable predictors to identify the most promising wetting agent for a given coal.

As mentioned for foam application in Chapter 3, the potential effects on miner’s health and impact on coal cleaning operations must be considered before using chemical additives.

## Roof Bolter Dust Control

As noted at the beginning of this chapter, RB operator occupations have had the highest quartz exposure on CM sections and have multiple sources of dust exposure. From the RB, drilling into the roof rock can obviously be a significant source of quartz exposure, as can be emptying the dust collector box. Also, dust captured by the drill collector but not removed from the airstream can be discharged back into the ambient mine air. In addition to sources at the RB, working downwind of the CM can lead to elevated quartz exposure, particularly if the CM is not using a flooded-bed scrubber. A number of technologies and practices have been developed to reduce dust exposures from these sources and each are discussed below.

### Efficient Drilling and Dust Confinement

As previously indicated, a primary goal of reducing respirable dust exposure should be to minimize the amount of respirable dust being generated by any dust-producing activity. If the dust is not generated, it does not have to be managed with other control technologies. For roof bolters, this means efficient drilling with sharp bits and drilling parameters adjusted for the type of rock being drilled into.

In the United States, most underground coal mines use roof bolters with dry dust collectors and tungsten carbide-tipped drill bits. As shown in Figure 4.17, left and right, sharp carbide cutting inserts are mounted on top of a steel bit body, with the carbide designed to cut into the roof rock during drilling. As the carbide loses its sharp cutting edge (Figure 4.17, left center), drilling penetration will be reduced, leading to greater dust generation as the bit grinds rather than efficiently cuts into the rock. Consequently, sharp drill bits should always be used to minimize dust generation and maintain penetration rate.



Photo by Kennametal

Photo by BCR National Laboratory

Photo by U.S. Synthetic

Photo by Kennametal

**Figure 4.17. New (left) and worn (left center) tungsten carbide dust hog style bits, polycrystalline diamond (PCD) dust hog bit (right center), and shank-style bit (right).**

The most commonly used RB drill bits are “dust hog” style bits, which have dust collection ports in the bit body as shown with the three bits on the left in Figure 4.17. The dust capture ports in dust hog style bits are adjacent to the cutting inserts when compared to a shank-type bit as shown

in Figure 4.17, right, which requires the dust capture port to be located in the drill steel. The location of the dust port is particularly important as drilling is initiated. Studies have shown that the greatest respirable dust generation occurs when drilling the first few inches of a hole as the drill bit initiates drilling into the roof rock but before being confined within the hole [Colinet et al. 1985]. With the dust collection ports in the bit body, more effective dust capture begins earlier during the dustiest part of drilling. This finding led to respirable dust reductions of 75% to 91% with one-inch-diameter dust hog bits when compared to shank bits under similar operating conditions during the first 12 inches of drilling [Colinet et al. 1985]. Underground testing of numerous dust hog and shank bits also indicated that dust hog bits drilled 25% faster in hard roof [Divers et al. 1986].

An alternative to carbide-tipped bits are drill bits with polycrystalline diamond (PCD) cutting inserts. When tested with wet drilling, these bits demonstrated an ability to substantially extend bit life with less wear when compared to shank-style carbide tipped bits [USBM 1992b]. However, this testing indicated that specific operating parameters (rpm, thrust, and water pressure) needed to be maintained to prevent the brittle PCD bits from fracturing. PCD bits are available for dry drilling applications as shown in Figure 4.17, center right. Limited testing for dust generation when comparing the PCD bit design to dust hog bits resulted in inconsistent sampling conditions and mixed results [Seiter et al. 2015].

As mentioned, there is no confinement at the drill bit when drilling first begins, and dust can easily be liberated into the ambient air. A bit sleeve can be used to help confine dust during this initial portion of drilling and reduce dust levels [Beck 2015]. The bit sleeve system contains a 3.5-inch-long metal cylinder, a metal clip, and large washer as shown in Figure 4.18, left. The washer, clip, and bit sleeve are placed on the drill steel as shown in Figure 4.18, center. The washer is then used to push the bit sleeve up to the roof before the start of drilling with the metal clip holding the bit sleeve in place as shown in Figure 4.18, right. With the bit sleeve providing dust confinement during the first few inches of drilling, respirable dust levels were reduced by 57% during the first 12 inches of drilling into concrete during laboratory testing [Beck 2015].

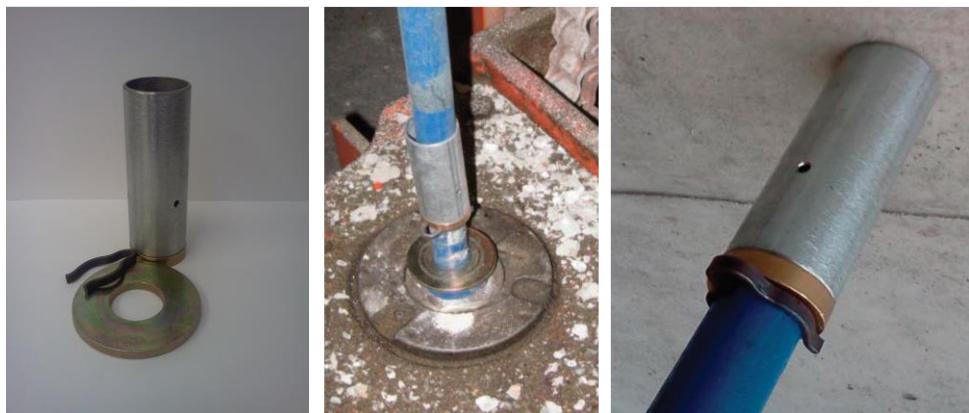

Photos by NIOSH

**Figure 4.18. Components of drill bit sleeve (left), installed on a drill steel (center), and bit sleeve raised to roof (right).**

In addition to cutting with sharp bits, the drill feed rate, bit rotation speed, and torque may be adjusted to maximize efficient cutting [Cotton et al. 2015]. Some of the reported benefits of optimizing these drilling parameters included increased bit life, reduced clogging of the



vacuum system and dust blowout from the drill hole, reduced hanging of drill steels in holes, reduced noise, and increased particle size of drill cuttings, which reduces fine dust generation. Slowing bit rotation with a similar thrust allows each rotation of the bit to take a deeper bite into the roof rock, creating greater penetration and less respirable dust [Jiang et al. 2018]. A computer-controlled drilling system that uses real-time feedback on drilling parameters is available but has not gained widespread use [Burgess 2020].

### Dry Vacuum Dust Collector

Dry vacuum dust collection systems have historically been used on roof bolters in U.S. underground coal mines. These systems are designed to pull dust generated by drilling through a hollow drill steel and rubber hoses back to a pre-cleaner and collector box. The pre-cleaner is a cyclone designed to remove larger particles from the airstream to reduce dust loading of the collector box. The collector box has multiple chambers and contains a cyclone and final canister filter, which are used to remove the captured dust from the airstream. The filtered air is then discharged through a muffler back into the ambient mine air. Figure 4.19 illustrates the various components of the dry vacuum system. Past research has shown that when this system is operating properly it can be very effective in controlling dust generated by drilling [Beck and Goodman 2008].

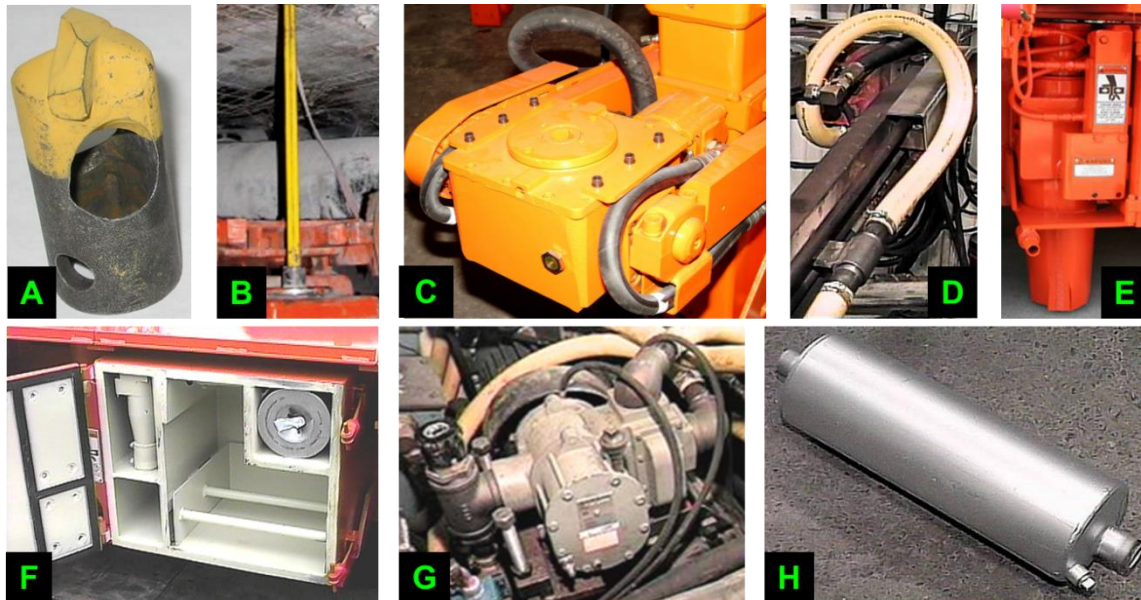

Photos A-B by NIOSH

Photos C-H by J.H. Fletcher & Co.

**Figure 4.19. Components of a dry vacuum dust collection system. Dust-laden air is drawn through the bit (A), drill steel (B), drill head (C), hoses (D) to the pre-cleaner (E), and to the dust box (F) by the blower (G) before filtered air is discharged through the muffler (H) back into the mine air.**

A vacuum gauge should be placed in the drill chuck to periodically measure the vacuum being generated at the drill head as shown in Figure 4.20, left. The minimum required blower vacuum is specified on the dust certification plate mounted on the bolting machine and in the mine's ventilation plan. This minimum vacuum must be maintained to achieve the desired airflow through the system. If the minimum is not achieved, the collector box should be cleaned, the

collector box gaskets (Figure 4.20, center) should be inspected for integrity, and checks should be made throughout the system for loose or damaged hoses. Smoke tubes can be used to help identify leaks in the system as shown in Figure 4.20, right.



**Figure 4.20. Methods to ensure dust collector performance. A gauge is placed in the drill chuck to measure vacuum at the drill head (left), gaskets (in black) on the door of dust collector box are checked (center), and smoke tubes can be used to check for leaks in the system (right).**

### *Cleaning the Dust Box*

Frequent cleaning of the dust collector box is necessary to ensure proper operation of the dust collection system. When opening the dust box, collected dust can spill out onto the mine floor, as shown in Figure 4.21, left. Historically, the roof bolter operator would then clean dust out of the box by using a wooden wedge or other type of rake to scoop dust out by hand (Figure 4.21, center) or by pulling an insert out of the box (Figure 4.21, right.)



**Figure 4.21. Dust dropping out of dust box (left), operator cleaning dust box by hand (center), and insert used to assist in cleaning of dust box (right).**

These actions can create a dust cloud in the breathing zone of the operator and contaminate his or her clothing. Although this cleaning task typically only lasts a few minutes, research has shown that airborne respirable dust levels between 6 and 14 mg/m<sup>3</sup> can be present [Goodman and Organiscak 2002]. Also, after work clothes become contaminated, past studies [Butterworth and Donoghue 1970; USBM 1986] have shown that movement by the worker can result in dust being released from the clothes back into the air. A more recent study examined dust release from clothing contaminated with a mixture of monodisperse silica particles of 3, 5, and 10 μm

[McDonagh and Byrne 2014]. Results indicated that the resuspended fraction from contaminated clothing was approximately 30% on average, with up to 67% of the deposited dust being released during high physical activity. A NIOSH study monitored the dust exposure of two workers simultaneously performing the same job task in a confined area [Cecala et al. 2017]. Both workers were wearing hooded sweatshirts, with one sweatshirt being visibly dusty. Instantaneous dust sampling results showed the average dust levels over a defined work period were  $73.6 \mu\text{g}/\text{m}^3$  for the worker with the dusty sweatshirt compared to  $26.5 \mu\text{g}/\text{m}^3$  for the second worker.

Not surprising, analysis of collector box dust has also shown that elevated silica content can be found in this dust with an average of 26% silica in one study [Joy et al. 2010] and approximately 45% in another study [USBM 1990a]. Therefore, it is important to use proper cleaning procedures to minimize initial operator dust exposure and to avoid contamination of clothing to prevent resuspension of dust throughout the work shift.

Ideally, cleaning should take place in a well-ventilated entry with the RB operator positioned on the upwind side of the collector so that the liberated dust cloud is quickly removed from the operator's breathing zone. If a rake is used to pull dust from the main compartment, an extended handle should be used so that dust does not contaminate the operator's clothing. When emptying dust boxes on a dual-boom roof bolter, the return-side operator should empty the collector box first and then take a position on the intake side of the entry until the intake-side box is emptied. For additional protection, a respirator can be worn during the cleaning procedure.

### *Dust Collector Bags*

The dry dust collector box can be fitted with a bag similar to a vacuum cleaner bag (Figure 4.22, left) that captures dust in the main compartment of the collector. Use of the collector bag confines dust to reduce dust exposures when cleaning the dust box and speeds up the cleaning effort. This system is a retrofit option for most existing RBs and can also be supplied with new bolters. This system uses a nozzle (Figure 4.22, center), which is installed in the center compartment of the collector. The bag is attached to this nozzle to capture dust (Figure 4.22, right) before it reaches the filter cartridge. Use of the collector bag also prevents dust from being deposited into the roadway and potentially entrained into the ventilating air. It is recommended that a pre-cleaner cyclone be used to reduce loading of the bag with larger material.

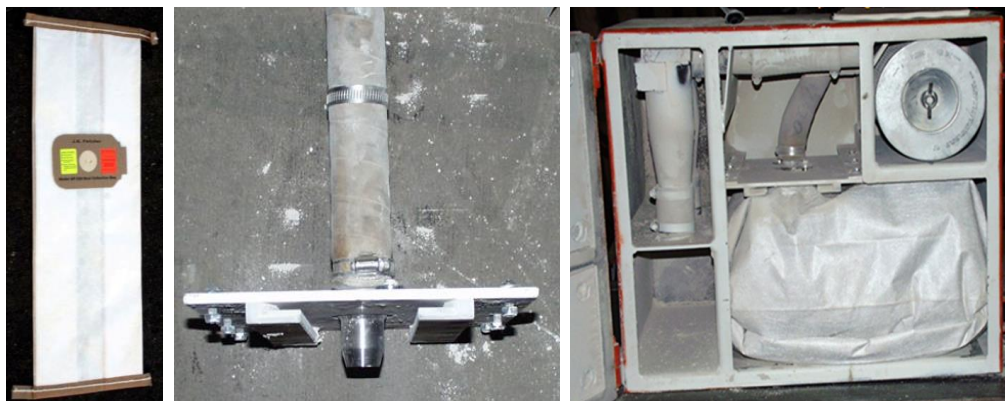

Photos by NIOSH

**Figure 4.22. Dust collector bag (left), bag nozzle (center), and bag positioned in collector box and filled with dust (right).**



When using collector bags in laboratory testing, dust loading and pressure drop on the canister filter were substantially reduced, indicating the canister filter would need to be changed less frequently [Listak and Beck 2008]. As part of this research, testing of the collector bags was completed at one mine and indicated that the collector bag reduced dust emissions in the bolter exhaust by approximately 85%. Collector box cleaning time was reduced from 4 minutes to 30 seconds.

### *Final Canister Filter*

In past practice, canister filters were removed and struck against a surface such as the bolter tire to dislodge caked dust from the filter media. The filter was then reinserted into the collector box. Unfortunately, this practice can create a dust cloud that contaminates the breathing zone and the clothes of the RB operators. Cleaning the filter in this manner also creates the potential for contaminating the collector's downstream discharge components (vacuum pump and muffler) with respirable dust. If improperly installed, dust can leak past the filter cartridge. When the downstream components become contaminated, respirable dust is discharged back into the mine environment in the collector's exhaust [USBM 1990a]. To rectify this hazardous condition, the downstream components must be removed and cleaned as described in the next section. NIOSH, MSHA, and RB manufacturers recommend that contaminated filters be removed and replaced with new filters to minimize worker dust exposures. Replacement of filter canisters should be completed in well-ventilated entries.

### *Cleaning the Discharge Side of the Collector*

If the discharge side of the collector system becomes contaminated due to collector filter damage and/or leaks, all components downstream of the collector box must be removed and flushed with water. Surveys have shown that removing and cleaning contaminated components downstream of the canister filter results in major improvements in dust and silica levels emitted from the collector's discharge [Thaxton 1984].

### *Pre-cleaner Dust*

The pre-cleaner is a cyclone designed to remove larger particles from the dust collector airstream prior to this dust entering the collector box. The pre-cleaner automatically dumps collected dust at regular intervals or is triggered by an action of the RB, such as raising the stab jack. The goal is to reduce dust loading in the collector box.

Some concern was expressed by mine operators regarding potential dust exposure for the RB operators resulting from the pre-cleaner discharging dust onto the mine floor. MSHA analysis of the dust from the pre-cleaner indicated that less than 2% of the dust was in the respirable size range [Fletcher 2000]. NIOSH conducted an evaluation of the dust dumped by the pre-cleaner and monitored dust levels at the pre-cleaner and RB operator locations [Joy et al. 2010]. Results of 46 samples collected from four MSHA districts indicated that the pre-cleaner dust contained respirable-sized dust (5%–35%) but less than the dust in the collector box (13%–87%), indicating that the cyclone was removing mainly larger particles as designed. Respirable dust sampling results from three mining sections did not reveal noticeable increases in airborne respirable dust concentrations at the pre-cleaner or operator positions when the pre-cleaner emptied dust onto the mine floor. Brattice or rubber can be installed as a skirt on the pre-cleaner dump to help contain the dust as it falls to the mine floor.



## Wet and Mist Drilling

For wet drilling, water is pumped to the drilling interface through the drill steel, captures dust, and then flows out of the drill hole. Successful dust control with wet drilling typically requires that approximately 2 gallons per minute (gpm) of water be supplied to the drill hole, with larger quantities required for acceptable drilling rates in harder roof rock [Divers et al. 1986]. Although wet drilling can effectively control dust emissions, this option can create difficult working conditions for RB operators and lead to problematic water accumulation on the mine floor.

Mist drilling reduces water usage when compared to wet drilling while attempting to maintain effective respirable dust control. Reduced quantities of water along with compressed air are supplied to the drilling interface through ports in the drill bit in an effort to capture dust. Mist drilling typically uses less than 0.5 gpm. Although more desirable from an operations perspective, mist drilling was not as effective in controlling airborne respirable dust when compared to properly operating dry vacuum systems in laboratory and mine testing [Beck and Goodman 2008].

## Working Downwind of the Continuous Miner

As shown in Figure 4.11 and reported in other NIOSH research [Goodman et al. 2006; NIOSH 2013; Organiscak et al. 2016], working downwind of the CM can result in exposure to elevated respirable dust levels, particularly if the CM is not operating a flooded-bed scrubber. Regardless of the type of face ventilation being used, the CM cutting sequence should be designed to eliminate or limit the amount of time the RB operators work downwind of the CM. The number of cuts that can be bolted downwind is specified in the MSHA-approved ventilation plan and is typically limited to a maximum of one cut per shift for most operations.

If the RB must work downwind of the CM, a cut sequence should be developed that maximizes the distance between the CM and RB faces. Increasing this distance will allow for greater mixing and dilution of the dust generated by the CM before it reaches the bolting face [Organiscak et al. 2016]. Also, the RB operators should move out of the return air of the CM immediately after completing bolting in the face. NIOSH has observed RB operators remaining in return air while waiting for the CM to complete a cut, which adds to their dust exposure.

A dry dust collector has been developed for use when bolter operators are working downwind of the CM. This technology is discussed in the Emerging Control Technologies for Continuous Mining Sections section at the end of this chapter. Also, canopy air curtain technology provides protection from respirable dust for RB operators and is discussed next.

## Canopy Air Curtain

The canopy air curtain is an engineering control that can be used to provide protection from dust generated during drilling and dust generated by the CM when the RB is located downwind of the CM. A centrifugal fan draws ambient air from the mining entry through a filter and blows this air down over the RB operator through a plenum mounted on the underside of the canopy as illustrated in Figure 4.23. The plenum is ideally the same shape as the RB canopy and is equipped with internal baffles and a series of holes in the bottom plate to distribute the filtered air across the entire plenum. Therefore, protection is provided to the operator while positioned under any portion of the canopy.

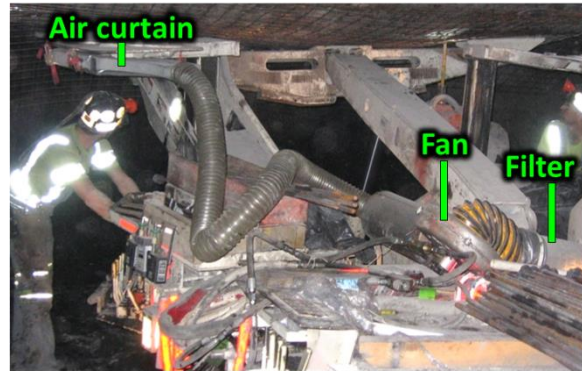
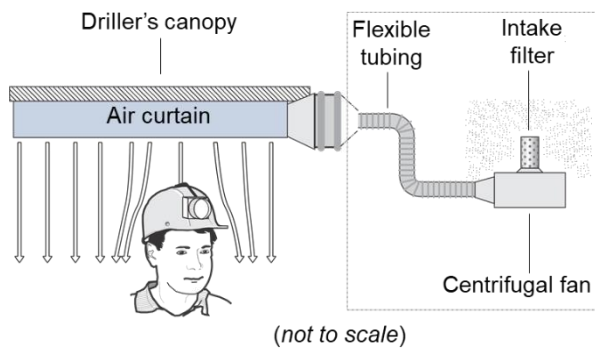

Photo by NIOSH

**Figure 4.23. Schematic illustrating canopy air curtain components and operating principle (left) and being tested at an underground mine (right).**

Laboratory testing with 350 cfm provided to the canopy air curtain resulted in respirable dust reductions up to 75% at mean entry air velocities from 60 to 120 fpm [Listak and Beck 2012]. The dust reductions were calculated by comparing dust levels outside of the canopy air curtain to levels measured 10 inches below the canopy. Initial mine tests were shortened due to a damaged fan but resulted in respirable dust reductions of 35% to 53% for the two faces that were bolted. The canopy air curtain underwent several design modifications, including designs developed by an RB manufacturer, before NIOSH conducted additional tests at a coal mine. During three shifts of testing, the RB was never downwind of the CM. Therefore, dust levels below  $0.5 \text{ mg/m}^3$  were observed for all cuts sampled and below  $0.1 \text{ mg/m}^3$  for many of the cuts bolted. As a result, varied results were obtained with such low dust levels, but maximum dust reductions up to 60% were observed [Reed et al. 2019].

The canopy air curtain technology has been adopted by J.H. Fletcher & Co. and incorporated into the canopy designs for the company's roof bolting machines as shown in Figure 4.24. Canopy air curtains can be installed as retrofits or incorporated into new machines.



Photos by NIOSH

**Figure 4.24. Canopy air curtains installed on roof bolters at two underground coal mines.**

## Shuttle Car Dust Control for Blowing Face Ventilation

As previously discussed, shuttle car operators are positioned in return air when blowing face ventilation is used and are at risk for elevated dust exposure. Several operational items can be implemented to lower the dust exposure for these operators:

- Shuttle car operator cabs should be located on the side of entry where the intake air is delivered to the face by line curtain or tubing. MSHA sampled dust levels on each side of entry and found lower concentrations ranging from 33% to 90% on the intake side. [Schultz and Fields 1999].
- Shuttle car operator cabs should not be located in the direct discharge air of the dust scrubber on the continuous miner.
- The shuttle car routes between the CM and feeder should be configured to minimize the amount of time the shuttle cars spend in return air.

NIOSH recently completed laboratory testing in a full-scale CM dust gallery to evaluate the impact on shuttle car operator dust levels of changing several engineering controls. Blowing face ventilation of 8,000 and 12,000 cfm was evaluated, while the CM scrubber was operated at 7,000 cfm. Combinations of face air quantities, curtain setback distances of 30 and 50 feet, and with/without blocking sprays operating on the sides of the CM were tested. Shuttle car operator dust levels were lowered for face airflow of 12,000 cfm with a 50-foot curtain setback and the blocking sprays operating [Klima et al. 2019].

## Maintenance of Dust Controls

To realize the greatest and ongoing benefit from applied dust controls, maintenance of the controls must be a priority for both management and miners. Mine management must provide the supplies and time to conduct required maintenance, and miners must recognize when controls have been compromised and require maintenance.

As was noted for flooded-bed scrubber airflow, the performance of an effective dust control can be substantially degraded if the proper maintenance is not completed in a timely manner. The need to conduct maintenance on dust control technologies cannot be overemphasized as a key factor for minimizing dust exposures.

## Emerging Control Technologies for Continuous Mining Sections

### Self-cleaning Nozzles

One concern with the use of underboom sprays on CMs is the need to safely perform maintenance on clogged sprays. The cutting boom must be supported for personnel to safely access the sprays, which may result in less frequent maintenance. A potential solution is the development of a self-cleaning spray nozzle manufactured by Repair King. NIOSH conducted laboratory tests to compare the water flow rate, airflow induction, and airborne respirable dust capture efficiency of two differently sized hollow cone Repair King nozzles with two similarly sized hollow cone nozzles, each from Spraying Systems Co. and Steinen-Hahn, whose sprays are commonly used in underground coal mines [Klima et al. 2017]. Results of this testing showed the self-cleaning sprays had similar water flow rates and airflow induction as the other two nozzles, but airborne dust capture was approximately 25% less. Therefore, these sprays appear to

be equivalent to the other sprays for wetting applications but not airborne dust capture. NIOSH conducted lab tests to evaluate general performance of these nozzles. The self-cleaning potential of the Repair King sprays needs to be assessed in operating mines for reduced clogging potential.

## Dry Scrubber

As noted previously, a potentially large source of dust exposure for RB operators is working downwind of the CM. To address this issue, NIOSH issued a research contract to J.H. Fletcher & Co. to develop a stand-alone, mobile dry scrubber (DS) dust collector that could be positioned to clean the return air from the CM and provide filtered air to the RB operators. Figure 4.25, left, shows how the DS could be positioned to provide filtered air to the RB operators.

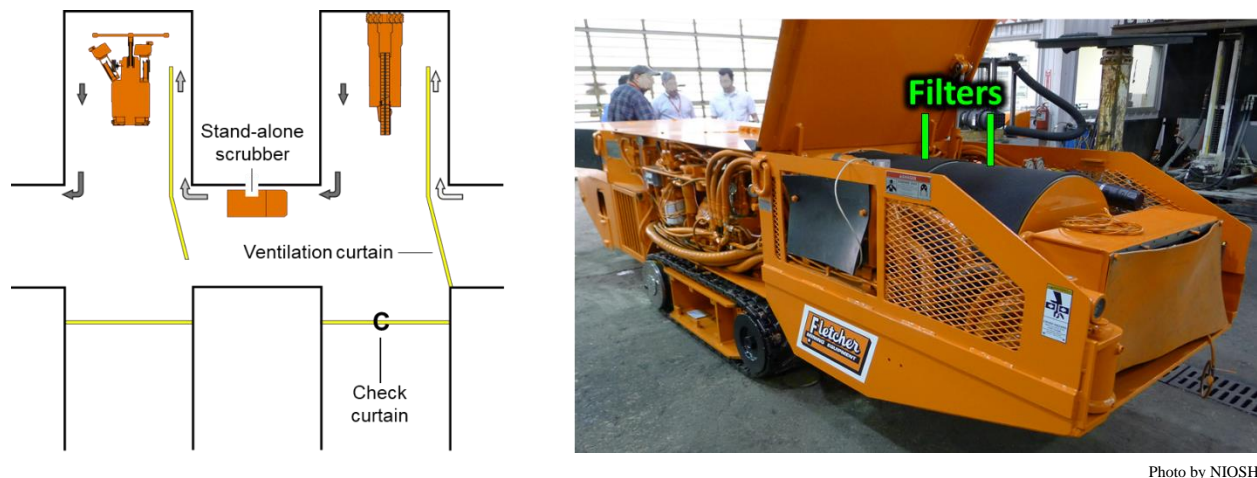

**Figure 4.25. Positioning of dry scrubber to provide filtered air to roof bolter operators (left) and dry scrubber with cover raised to show filters (right).**

The DS prototype shown in Figure 4.25, right, is a 4-ft-wide by 4-ft-high by 16-ft-long crawler-driven unit equipped with a 30-hp vane axial fan and variable frequency drive (VFD) controller.

The VFD is designed to automatically adjust the fan to maintain the user-specified air quantity as dust buildup occurs on the filters. The fan is capable of pulling between 3,000 and 9,000 cfm through the scrubber. The unit contains two 28-inch outer diameter cylindrical filters that are rated at 99% efficiency for 2- $\mu\text{m}$  sized particles. The discharge from the scrubber can be fitted with a removable steel duct to turn the discharge air 90 degrees. A remote-control module is used to tram the unit.

NIOSH initially conducted laboratory testing to evaluate the performance characteristics of the DS. In the controlled laboratory tests, the DS averaged over 95% respirable dust removal efficiency at both the low and high airflows [Organiscak et al. 2016]. After the eighth hour of dust testing at an airflow setting of 8,500 cfm, the pressure differential across the filters increased so that the DS airflow started to drop (8,420 cfm) below the setpoint as the fan reached its maximum adjustment.

Underground testing was conducted on two super sections that were using blowing face ventilation with line curtain. The DS was positioned in the last open crosscut to clean the return air from the CM and blow filtered air into the face with the 90-degree duct attached. Respirable



dust sampling conducted upwind of the DS and at the face showed a 50% reduction in respirable dust with the DS operating between 2,700 to 4,900 cfm [Organiscak et al. 2016].

Approval for use in underground coal mines was obtained from MSHA, and the DS is commercially available.

### Wet Collector Box

As noted previously, dry vacuum dust collection systems are traditionally used on RBs in the United States. When properly operating, dry collectors have been shown to be effective for controlling dust at the drill hole. However, the dust box must be cleaned periodically and is a potential source of dust exposure, which can contain elevated levels of quartz.

An alternative that modifies the dry collection box has been evaluated with the mine receiving permission from MSHA to modify its dry collector for testing. A vacuum is still created at the drill hole to pull dust-laden air back to the collector box. However, the box has been modified by removing the internal cyclone, the lower section of the metal compartment divider, and adding a water spray, drain valve, and angled plates in the bottom panel of the collector box as shown in Figure 4.26, left. The water spray nozzle was operated at a flow rate of 0.5 to 2.0 gpm at 100 psi to wet the dust as it entered the collector box. Water was supplied to the RB through a hose connected to the water line for the CM. A water-resistant canister filter has been developed by the RB manufacturer and was used in this testing. After bolting each cut, the RB operator would activate a hydraulically controlled drain valve at the bottom of the collector box to drain the saturated dust, which is shown in Figure 4.26, right. Remaining material can be rinsed out with a water hose tapped into the water feed to the RB. Since the dust is saturated, little or no dust should become airborne during this cleaning.

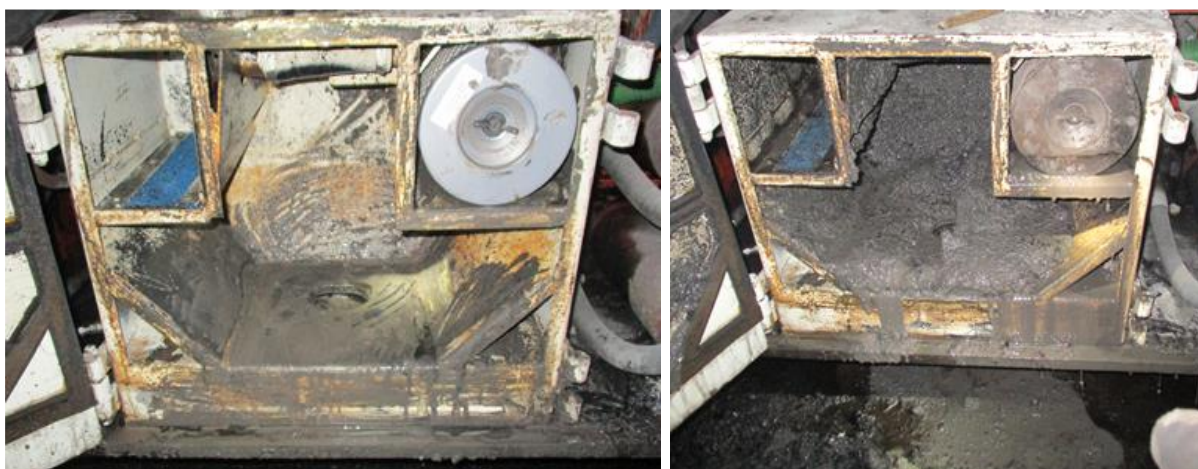

Photos by NIOSH

**Figure 4.26. Wet collector box on roof bolter (left) and wetted material in collector box (right).**

Sampling was conducted by NIOSH at an underground mine to compare dust levels from a wet collector box to the standard dry collector box [Reed et al. 2021a]. A vest was equipped with gravimetric samplers and worn by the RB operators only during dust box cleaning to isolate dust exposure during this activity. Personal dust monitor (PDM) samplers were worn by the RB operators throughout their bolting shift to measure overall dust exposure while on the section. Sampling results showed that the use of the wet collector box reduced operator dust levels during

box cleanout by an average of 80% over three sampling shifts, while overall shift dust reductions from the PDM samples averaged over 25%. Also, the use of the wet collector box reduced the quartz content in the gravimetric samples collected during box cleanout from an average of 7.4% with the dry collector to below detectable levels with the wet box.

J.H. Fletcher & Co. has submitted this wet box design to MSHA seeking approval for use in underground coal mines.

### Shuttle Car Canopy Air Curtain

The canopy air curtain has demonstrated the ability to lower the dust exposure of RB operators. In an effort to lower the dust exposure of haulage car operators, particularly when blowing face ventilation is used, NIOSH wanted to adapt the canopy air curtain for use on haulage cars. NIOSH issued a contract to Marshall University with J.H. Fletcher & Co. as a subcontractor to design, fabricate, and install a canopy air curtain on a haulage car in an underground coal mine. NIOSH conducted laboratory testing of this air curtain design and then in-mine testing with it installed on the canopy of a ram car (battery hauler) as shown in Figure 4.27, left.



Photos by NIOSH

**Figure 4.27. Canopy air curtain installed on underside of ram car canopy (left) and showing how filtered air is blown down over operator's position, along with a dust sampling package located outside of cab (right). White arrows indicate airflow.**

A sampling package containing two gravimetric pumps/filters and a personal DataRAM (pDR) instantaneous sampler was located just outby the operator's compartment as shown in Figure 4.27, right. While in the cab, the operator wore a pDR unit. In addition, a PDM unit was placed on the floor of the operator's cab with the PDM sampling inlet clipped to the operator's lapel. The gravimetric-based samplers at each location were used to determine calibration factors for the pDR during each sampling shift. The pDR was set to record a respirable dust reading every two seconds, which would typically generate 20 to 30 sampling points, while the ram car was being loaded behind the miner, which was the primary dust source. Sampling results were also analyzed for when the ram car was tramming to and from the feeder-breaker and during unloading at the feeder-breaker [Reed et al. 2021b].

With the canopy air curtain providing over 300 cfm of airflow, sampling results indicate that an average dust reduction of 65% was observed for the ram car operator when loading behind the

CM. While tramming to the feeder-breaker, unloading, and tramming back to the CM, average dust reductions of 18%, 36%, and 24% were measured, respectively. Dust reductions were lower while tramming as the air discharged from the canopy air curtain had to compete with the entry air velocity combined with the air velocity created by the ram car tramming. These results indicate that a canopy air curtain installed on haulage vehicles can successfully reduce operator dust exposures.

## References for Chapter 4

- 79 Fed. Reg. 24814 [2014]. Mine Safety and Health Administration: Lowering miners' exposure to respirable coal mine dust, including continuous personal dust monitors; final rule. To be codified at 30 CFR Parts 70, 71, 72, 75, and 90.
- Ainsworth SM, Gero AJ, Parobeck PS, Tomb TF [1995]. Quartz exposure levels in the underground and surface coal mining industry. *Am Ind Hyg Assoc J* 56(10):1002–1007.
- Beck TW, Goodman GVR [2008]. Evaluation of dust exposures associated with mist drilling technology for roof bolters. *Min Eng* 60(12):35–39.
- Beck TW [2015]. Evaluations of bit sleeve and twisted-body bit designs for controlling roof bolter dust. *Min Eng* 67(2):34–40.
- Beck TW, Organiscak JA, Pollock DE, Potts JD, Reed, WR [2016]. Influence of continuous mining arrangements on respirable dust exposures. *Society for Mining, Metallurgy & Exploration, Transactions Vol. 340*, pp. 1–10.
- Burgess T [2020]. E-mail message from Tim Burgess, Executive Vice President of Engineering, J.H. Fletcher & Co. to Jay Colinet, NIOSH, July 7.
- Butterworth R, Donoghue JK [1970]. Contribution of activity released from protective clothing to air contamination measured by personal air samplers. *Health Phys* 18(4):319–323.
- Campbell JAL, Moynihan DJ, Roper WD, Willis EC [1983]. Dust control system and method of operation. U.S. Patent 4,380,353. Washington, DC: U.S. Patent and Trademark Office.
- Cecala AB, Haas EJ, Patts JR, Cole GP, Azman AS, O'Brien AD [2017]. Helmet-CAM: an innovative tool for exposure assessment of respirable dust and other contaminants. In *Proceedings of the 16th North American Mine Ventilation Symposium*, Golden, CO, June 17–22, pp. 13-1 to 13-12.
- CFR. Code of Federal regulations. Washington, DC: U.S. Government Printing Office, Office of the Federal Register.
- Chander S, Alaboyun AR, Aplan FF [1991]. On the mechanism of capture of coal dust particles by sprays. *Proceedings of the 3rd Symposium on Respirable Dust in the Mineral Industries*, Pittsburgh, PA, October 17–19, pp.193–202.
- Colinet JF, Shirey GA, Kost JA [1985]. Control of respirable quartz on continuous mining sections. U.S. Department of the Interior, Bureau of Mines Open File Report 29-86, NTIS No. PB/86-179546.
- Colinet JF, Jankowski RA [1996]. Dust control considerations for deep-cut faces when using exhaust ventilation and a flooded-bed scrubber. *Society for Mining, Metallurgy, and Exploration, Transactions Vol. 302*, pp. 104–111.
- Colinet JF, Jankowski RA [2000]. Silica collection concerns when using flooded-bed scrubbers. *Min Eng* 52(4):49–54.
- Cotton D, Burgess T, Martin T [2015]. Optimizing drilling parameters for improved bolting safety and performance. *34th International Conference on Ground Control in Mining*, Morgantown, WV, July 28–30, pp. 330–336.



- Defibaugh J [2018]. E-mail message from Joe Defibaugh, Engineer—Dust & Ventilation, Komatsu Mining Corp. to Jay Colinet, NIOSH, September 10.
- Defibaugh J [2020]. E-mail message from Joe Defibaugh, PDTC Group Leader, Komatsu Mining Corp. to Jay Colinet, NIOSH, May 18.
- Defibaugh J [2021]. E-mail message from Joe Defibaugh, PDTC Group Leader, Komatsu Mining Corp. to Jay Colinet, NIOSH, January 4.
- Divers EF, Organiscak JA, Hilton T [1986]. Bolt faster, cut bit costs in hard roof. *Coal Age* 91(7):54–55.
- Feldstein N [1981]. Surface chemical technology for improved wetting of coal dust. U.S. Department of the Interior, Bureau of Mines Open File Report 127-81, NTIS No. PB82-104654.
- Fletcher [2000]. Dust collection systems. Fletcher Product Newsletter, Huntington, WV, Q1.
- Goodman GVR, Listak JM [1999]. Variation in dust levels with continuous miner position. *Min Eng* 51(2):53–59.
- Goodman GVR [2000]. Using water sprays to improve performance of a flooded-bed dust scrubber. *Appl Occ Env Hyg* 15(7):550–560.
- Goodman GVR, Organiscak JA [2002]. Evaluation of method for controlling silica dust exposures on roof bolters. *Society for Mining, Metallurgy, and Exploration, Transactions* Vol. 312, pp. 133–137.
- Goodman GVR, Pollock DE [2004]. Use of a directional spray system design to control respirable dust and face gas concentrations around a continuous mining machine. *J Occup Env Hyg* 1(12):806–815.
- Goodman GVR, Beck TW, Pollock DE, Colinet JF, Organiscak JA [2006]. Emerging technologies control respirable dust exposures for continuous mining and roof bolting personnel. In: Mutmanský JM, Ramani RV eds. *Proceedings of the 11th U.S./North American Mine Ventilation Symposium*, University Park, PA, June 5–7, pp. 211–216.
- Hall NB, Blackley DJ, Halldin CN, Laney AS [2019]. Continued increase in prevalence of r-type opacities among underground coal miners in the USA. *Occup Env Med* 76(7):479–481.
- Jayaraman NI, Kissell FN, Schroeder W [1984]. Modify spray heads to reduce dust rollback on miners. *Coal Age* 89(6):56–57.
- Jiang H, Luo Y, McQuerrey J [2018]. Experimental study on effects of drilling parameters on respirable dust production during roof bolting operations. *J Occup Env Hyg* 15(2):143–151.
- Joy GJ, Beck TW, Listak JM [2010]. Respirable quartz hazard associated with coal mine roof bolter dust. In: Hardcastle S, McKinnon DL, eds., *Proceedings of the 13th U.S./North American Mine Ventilation Symposium*, Sudbury, Ontario, Canada, June 13–16, pp. 59–64.
- Kissell FN, Schroeder W, Ruggieri S, Hoover S [1979]. Recent experience with the spray fan. *Proceedings of the 2nd International Mine Ventilation Congress*, Reno, NV, Nov 4–8, pp. 115–120.
- Klima S, Seaman C, Mischler S, Organiscak J [2017]. Comparison of different hollow cone water sprays for continuous miner dust control applications. *Society for Mining, Metallurgy, and Exploration Annual Meeting*, Denver, CO, February 19–22, Preprint 17-026.

Klima SS, Organiscak JA, Colinet JF [2019]. Reducing shuttle car operator dust exposure by improving continuous miner blowing face ventilation parameters. Society for Mining, Metallurgy, and Exploration Annual Meeting, Denver, CO, February 25–27, Preprint 19-078.

Kost JA, Shirey GA, Ford CT [1980]. In-mine tests for wetting agent effectiveness. U.S. Department of the Interior, Bureau of Mines Open File Report 30-82, NTIS No. PB82-183344.

Listak JM, Beck TW [2008]. Laboratory and field evaluation of dust collector bags for reducing dust exposure of roof bolter operators. *Min Eng* 60(7):57–63.

Listak JM, Goodman GVR, Beck TW [2010]. Evaluation of the wet head continuous miner to respirable dust. *Min Eng* 62(9):60–64.

Listak JM, Beck TW [2012]. Development of a canopy air curtain to reduce roof bolters' dust exposure. *Min Eng* 64(7):72–79.

McClelland JJ, Colinet JF, Bringham B [1991]. Performance evaluation of irrigated filters. Society for Mining, Metallurgy, and Exploration, Transactions Vol. 290, pp. 1828–1831.

McDonagh A, Byrne MA [2014]. The influence of human physical activity and contaminated clothing type on particle resuspension. *J Env Radioactivity* 127:119–126.

MSHA [2020a]. MSHA data sets—16. Quartz samples. U.S. Department of Labor, Mine Safety and Health Administration. <https://arlweb.msha.gov/OpenGovernmentData/OGIMSHA.asp>

MSHA [2020b]. Coal mine health inspection procedures, Handbook number:PH89-V-1 (27). U.S. Department of Labor, Mine Safety and Health Administration.

MSHA [2020c]. How to correctly determine dust scrubber air quantity. U.S. Department of Labor, Mine Safety and Health Administration, Pittsburgh Safety and Health Technology Center, <https://arlweb.msha.gov/S&HINFO/BlackLung/ControlDust2009/7%20Pitot%20Tube%20Measurements.pdf>

NIOSH [1997]. Exposure to silica dust on continuous mining operations using flooded-bed scrubbers. Cincinnati, OH: U.S. Department of Health and Human Services, Centers for Disease Control and Prevention, National Institute for Occupational Safety and Health, DHHS (NIOSH) Publication No. 97-147, Hazard Identification 1.

NIOSH [2011]. Evaluation of face dust concentrations at mines using deep-cutting practices. By Potts JD, Reed WR, Colinet JF. Pittsburgh, PA: U.S. Department of Health and Human Services, Centers for Disease Control and Prevention, National Institute for Occupational Safety and Health, DHHS (NIOSH) Publication No. 2011-131, Report of Investigations 9680.

NIOSH [2013]. Impact on respirable dust levels when operating a flooded-bed scrubber in 20-foot cuts. By Colinet JF, Reed WR, Potts JD. Pittsburgh, PA: U.S. Department of Health and Human Services, Centers for Disease Control and Prevention, National Institute for Occupational Safety and Health, DHHS (NIOSH) Publication No. 2014-105, Report of Investigations 9693.

Ondrey RS, Haney RA, Tomb TF [1995]. Dust control parameters necessary to control dust on longwall and continuous mining operations. Society for Mining, Metallurgy, and Exploration, Preprint 95-145.

Organiscak JA, Khair AW, Ahmed M [1996]. Studies of bit wear and respirable dust generation. Society for Mining, Metallurgy, and Exploration, Transactions Vol. 298, pp. 1874–1879.

- Organiscak JA, Beck TW [2010]. Continuous miner spray considerations for optimizing scrubber performance in exhaust ventilation systems. *Min Eng* 62(10):41–46.
- Organiscak JA [2013]. Examination of water spray airborne coal dust capture with three wetting agents. Society for Mining, Metallurgy, and Exploration, Transactions Vol. 334, pp. 427–434.
- Organiscak JA, Beck TW [2013]. Examination of redirected continuous miner scrubber discharge configurations for exhaust face ventilation systems. Society for Mining, Metallurgy, and Exploration, Transactions Vol. 334, pp. 435–443.
- Organiscak J, Noll J, Yantek D [2016]. Examination of a newly developed mobile dry scrubber (DS) for coal mine dust control applications. Society for Mining, Metallurgy, and Exploration, Transactions Vol. 340, pp. 38–47.
- Pollock DE, Potts JD, Joy GJ [2010]. Investigation into dust exposures and mining practices in mines in the southern Appalachian region. *Min Eng* 62(2):44–49.
- Reed WR, Klima S, Shahan M, Ross GJH, Singh K, Ross G, Grounds T [2019]. A field study of a roof bolter canopy air curtain (2nd generation) for respirable coal mine dust control. *Int J Min Sci Tech* 29(5):711–720.
- Reed WR, Klima S, Mazzella A, Ross G, Roberts G, Deluzio J [2021a]. A second case study of field test results for comparison of roof bolter dry collection system with wet collection system. Society for Mining, Metallurgy, and Exploration Annual Meeting, Denver, CO, March 1–5, Preprint 21-008.
- Reed WR, Colinet JF, Klima SS, Mazzella A, Ross G, Workman M, Morson T, Driscoll J [2021b]. Field test of a canopy air curtain on a Ramcar for dust control in an underground coal mine. Society for Mining, Metallurgy, and Exploration Annual Meeting, Denver, CO, March 1–5, Preprint 21-009.
- Reynolds LE, Blackley DJ, Colinet JF, Potts JD, Storey E, Short C, Carson R, Clark KA, Laney AS, Halldin CN [2018]. Work practices and respiratory health status of Appalachian coal miners with progressive massive fibrosis. *J Occ Env Med* 60(11):575–581.
- Roepke WW [1984]. General methods for primary dust control during coal cutting. *Min Eng* 36(6):636–644.
- Schultz MJ, Fields KG [1999]. Dust control considerations for deep cut mining sections. Society for Mining, Metallurgy, and Exploration Annual Meeting, Denver, CO, March 1–3, Preprint 99-163.
- Schultz MJ, Tomko DM, Rumbaugh VE [2010]. Utilizing adequate intake line curtain air quantities to maintain respirable dust compliance. In: Hardcastle S, McKinnon DL, ed. Proceedings of the 13th United States/North American Mine Ventilation Symposium, Sudbury, Ontario, Canada, June 13–16.
- Seiter J, Smith M, Kim E, Cox S [2015]. Dust and noise hazard exposure: Comparison of PDC vs. WC roof bolt bits in laboratory. *Min Eng* 67(2):28–33.
- Tessum MW, Raynor PC [2017]. Effects of spray surfactant and particle charge on respirable coal dust capture. *Safety and Health at Work* 8(3):296–305.  
<https://doi.org/10.1016/j.shaw.2016.12.006>

- Thaxton RA [1984]. Maintenance of a roof bolter dust collector as a means to control quartz. In: Proceedings of the Coal Mine Dust Conference, Morgantown, WV, October 8–10, pp. 137–143.
- Tien JC, Kim J [1997]. Respirable coal dust control using surfactants. *Appl Occup Env Hyg* 12(12):957–963.
- USBM [1969]. Face ventilation in underground bituminous coal mines: airflow and methane distribution patterns in immediate face area–line brattice. By Luxner JV. Pittsburgh, PA: U.S. Department of the Interior, Bureau of Mines, Report of Investigations 7223.
- USBM [1976]. Effect of location and type of water sprays for respirable dust suppression on a continuous mining machine. By Matta JE. Pittsburgh, PA: U.S. Department of the Interior, Bureau of Mines, Technical Progress Report 96.
- USBM [1983a]. Spray fan aids in effectively controlling methane. Pittsburgh, PA: U.S. Department of the Interior, Bureau of Mines, Technology News 162.
- USBM [1983b]. Laboratory tests for selecting wetting agents for coal dust control. By Zeller W. Minneapolis, MN: U.S. Department of the Interior, Bureau of Mines, Report of Investigations RI 8815.
- USBM [1985]. How twelve continuous miner sections keep their dust levels at 0.5 mg/m<sup>3</sup> or less. Pittsburgh, PA: U.S. Department of the Interior, Bureau of Mines, Technology News 220.
- USBM [1986]. Impact of background sources on dust exposure of bag machine operator. By Cecala AB, Thimons ED. Pittsburgh, PA: U.S. Department of the Interior, Bureau of Mines, Information Circular 9089.
- USBM [1989]. Underboom sprays reduce quartz dust on continuous mining machines. Pittsburgh, PA: U.S. Department of the Interior, Bureau of Mines, Technology News 323.
- USBM [1990a]. Sources and characteristics of quartz dust in coal mines. By Organiscak JA, Page SJ, Jankowski RA. Pittsburgh, PA: U.S. Department of the Interior, Bureau of Mines, Information Circular 9271.
- USBM [1990b]. Laboratory evaluation of quartz dust capture of irrigated-filter collection systems for continuous miners. By Colinet JF, McClelland JJ, Erhard LA, Jankowski RA. Pittsburgh, PA: U.S. Department of the Interior, Bureau of Mines, Report of Investigations 9313.
- USBM [1992a]. Dust considerations when using belt entry air to ventilate work areas. By Potts JD, Jankowski RA. Pittsburgh, PA: U.S. Department of the Interior, Bureau of Mines, Report of Investigations 9426.
- USBM [1992b]. Breakthrough in roof-bolt drilling technology provides 200 to 400 times greater bit life. Minneapolis, MN: U.S. Department of the Interior, Bureau of Mines, Technology News 401.
- USBM [1996]. Suppression of longwall respirable dust using conventional water sprays inoculated with surfactants and polymers. By Kilau HW, Lantto OL, Olson KS, Myren TA, Voltz JI. Minneapolis, MN: U.S. Department of the Interior, Bureau of Mines, Report of Investigations 9591.

## CHAPTER 5: CONTROLLING RESPIRABLE DUST AT SURFACE MINES

Workers at surface mines are involved in the drilling and removal of overburden rock, so exposure to respirable crystalline silica (quartz) is a major concern. NIOSH had previously called attention to 23 cases of silicosis found in surface drill operators, including two that died from silicosis before the age of 40 [NIOSH 1992]. Additional health surveillance studies of surface mine workers have documented the ongoing occurrence of lung disease from respirable dust exposures at surface mines, as follows:

- In 1996 and 1997, health screenings were conducted of current and former bituminous and anthracite surface coal miners in Pennsylvania [CDC 2000]. Data from 1,236 examined miners showed radiographic evidence of silicosis in 6.7% of these miners. Operation of a highwall drill had a significant impact on the prevalence of silicosis. For 792 miners reporting no drilling experience, silicosis was diagnosed in 4.7% of these miners. For the 26 miners that reported more than 20 years of drilling experience, 46% were diagnosed with silicosis.
- In 2010 and 2011, NIOSH obtained chest radiographs from 2,257 current surface coal miners with more than one year of experience from mines located in 16 different states [CDC 2012]. Forty-six of these workers were diagnosed with coal workers' pneumoconiosis, including 37 of the 46 that had never worked underground. Twelve of these miners were diagnosed with progressive massive fibrosis (PMF), including nine that never worked underground.
- From 2014 through 2019, NIOSH collected chest radiographs for 6,790 surface miners through the Coal Workers' Health Surveillance Program. Results showed that 109 miners had radiographic evidence of pneumoconiosis, including 12 with PMF [Hall et al. 2020].

This historic and recent data confirms that respirable dust exposure from surface mining alone is leading to severe lung disease.

With the passage of the Federal Coal Mine Health and Safety Act of 1969 (Public Law 91-173), a gravimetric sample containing over 5% quartz was considered excessive quartz exposure and resulted in the calculation and enforcement of a reduced respirable dust standard. This was an indirect means of limiting quartz exposure to a maximum of 100 micrograms per cubic meter of air ( $\mu\text{g}/\text{m}^3$ ). In 2014, the Mine Safety and Health Administration (MSHA) promulgated a dust rule [79 Fed. Reg.<sup>16</sup> 24814 (2014)] in which 100  $\mu\text{g}/\text{m}^3$  of quartz was specifically defined as the limit for quartz exposure and the threshold value for implementing a reduced dust standard. For samples collected after August 1, 2014, MSHA has reported both the quartz percentage and concentration.

Historically, highwall drill and bulldozer operators were occupations at risk for elevated respirable quartz dust exposure [Tomb et al. 1986; Tomb et al. 1995]. Consequently, in section 71.206 of the 2014 dust rule, MSHA identified these occupations as designated work positions (DWP) that must be sampled on a periodic basis. Inspector quartz sampling results for these two

---

<sup>16</sup> Federal Register. See Fed. Reg. in references.

DWP occupations were downloaded from the MSHA website [MSHA 2020] and analyzed based upon quartz content as shown in Table 5.1. This data analysis shows that 56% and 78% of bulldozer and highwall drill operator samples, respectively, contained greater than 5% quartz. Surprisingly, only 4.3% and 6.0% of these samples exceeded a quartz concentration above 100  $\mu\text{g}/\text{m}^3$ . MSHA data from 1988 to 1992 showed similar results for the percentage of samples exceeding 5% quartz for the bulldozer (71%) and highwall drill (82%) operators [Ainsworth et al. 1995]. However, the percentage of these samples exceeding 100  $\mu\text{g}/\text{m}^3$  was 10 times higher for both the bulldozer (45%) and drill operators (63%). This data suggests that application of respirable dust control technology over the past 25 years has led to reduced quartz dust exposures and highlights the importance of implementing successful control technologies at surface mines.

**Table 5.1. Quartz samples collected between August 1, 2014, and December 31, 2019, by MSHA inspectors for bulldozer and highwall drill operators [MSHA 2020]**

Quartz range, %	Number of bulldozer operator samples	Number > 100 $\mu\text{g}/\text{m}^3$	Percent > 100 $\mu\text{g}/\text{m}^3$	Average quartz, $\mu\text{g}/\text{m}^3$	Number of highwall drill operator samples	Number > 100 $\mu\text{g}/\text{m}^3$	Percent > 100 $\mu\text{g}/\text{m}^3$	Average quartz, $\mu\text{g}/\text{m}^3$
0.0–5.0	998	1	0.1	7	363	0	0.0	11
5.1–15.0	804	7	0.9	22	871	17	2.0	25
15.1–25.0	240	21	8.8	48	315	37	11.7	59
25.1–35.0	122	17	13.9	71	91	30	33.0	103
+35.1	108	52	48.1	123	35	16	45.7	140
Total	2,272	98	4.3	25	1,675	100	6.0	35

These high quartz percentages emphasize the importance of controlling respirable dust exposure from several main sources, including drilling, hauling, and dumping. A number of primary control technologies have been developed and successfully implemented by surface mine operations. These include isolating workers from dusty atmospheres, utilization of dust collectors, and wetting to suppress or capture dust. Application of dust controls for the various sources encountered at surface mines is discussed in the remainder of this chapter.

It should also be noted that surface mining for coal, metal, and nonmetal operations has many similarities, including applicable dust control technologies. As a result, some of the material presented in this chapter has been adapted from a recently updated dust control handbook for industrial minerals mining and processing [NIOSH 2019], NIOSH RI 9701, which can be accessed for additional information.



## Enclosed Cabs for Equipment Operators

### Performance Measures

For mobile equipment operators at surface mines, utilization of an enclosed cab with properly applied filtration and pressurization is likely the most important control that can be used to reduce operator dust exposures. An enclosed cab can isolate the equipment operator from dust present outside of the cab and provide a protected, conditioned work environment inside the cab. The same type of protection can be provided to operators in stationary booths, such as crusher operators. As with other control technologies discussed in this handbook, dust control efficiency can be calculated to evaluate enclosed cab performance. In addition, protection factor (PF) is another term often used to define enclosed cab performance. With respect to enclosed cabs, these performance measures are calculated with the following formulas:

$$\text{Efficiency (\%)} = \left( \frac{C - X}{C} \right) * 100$$

$$\text{Protection factor (PF)} = \frac{C}{X}$$

where C = respirable dust concentration outside of the cab and X = respirable dust concentration inside the cab. Table 5.2 shows the numerical relationship between these two measures. Throughout the remainder of this section, PF will generally be used to discuss enclosed cab performance.

**Table 5.2. Comparison of enclosed cab performance measures**

Efficiency, %	Protection factor
50	2
75	4
90	10
95	20
99	100
99.9	1,000

In addition to dust capture, filtration systems must provide enough intake air to prevent the build-up of carbon dioxide in the enclosed cab. A minimum intake air quantity of 25 cubic feet per minute (cfm) per person is recommended by the American Society of Agricultural and Biological Engineers (ASABE) [ASABE 2013].

### Cab Integrity

To optimize the protection afforded within an enclosed cab, effort should be made to ensure the integrity of the cab and the development of positive pressure within the cab. NIOSH found that a key to enclosed cab performance is to minimize the open spaces in the cab structure and potential dust leakage into the cab, particularly when high winds are present. In multiple field studies, it has been shown that development of positive pressure within the cab is a key factor in improving

the protection for the operator. Table 5.3 summarizes results from several NIOSH field studies where filtration and pressurization systems were retrofitted to existing cabs. The data is presented by increasing PF, with the equivalent efficiency value also listed for comparison.

This data illustrates the low levels of respirable dust that can be achieved inside of a properly sealed cab that develops positive pressure with an effective filtration and pressurization system installed. For the last three studies listed in Table 5.3, positive pressures in the cab were at 0.10 inches of water column (in. wc) or higher and resulted in PFs above 17, equivalent to dust control efficiencies in the mid to high 90s. Average dust levels inside the cab were equal to or less than 0.16 milligrams per cubic meter of air (mg/m<sup>3</sup>), despite average dust levels outside of the cabs being between 2.80 and 6.25 mg/m<sup>3</sup>.

**Table 5.3. Respirable dust sampling results for retrofitted filtration systems for enclosed cabs on mobile surface mining equipment**

Equipment tested	Reference	Cab pressure, in. wc	Average inside cab dust, mg/m <sup>3</sup>	Average outside cab dust, mg/m <sup>3</sup>	Protection factor	Efficiency, %
Rotary drill	Organiscak et al. [2004]	None detected	0.08	0.22	2.8	63.6
Haul truck	Chekan and Colinet [2003]	0.01	0.32	1.01	3.2	68.3
Front-end loader	Organiscak et al. [2004]	0.015	0.03	0.30	10.0	90.0
Rotary drill	Cecala et al. [2009]	0.10–0.40	0.16	2.85	17.8	94.4
Rotary drill	Cecala et al. [2003]	0.20–0.40	0.05	2.80	56.0	98.2
Rotary drill	Cecala et al. [2005]	0.07–0.12	0.07	6.25	89.3	98.9

Therefore, it is important to ensure that door gaskets are in good condition and that cracks/open areas in the cab structure are sealed as well as possible. Closed-cell foam and caulking can be used to seal these areas. It is also important to ensure that there are not leaks in the filtration and pressurization units. Periodic inspections should be completed to check gaskets and seals and look for signs of dust leakage into the system. Finally, if the cab is equipped with a window, it must be stressed to the operator that the window should not be opened as this compromises the system and allows dust to enter the cab. Opening of the door should also be minimized to maintain positive pressure and prevent dust infiltration into the cab.

A monitor can be installed to measure the differential pressure between the outside environment and the inside of an equipment cab. The monitor can show the equipment operator that positive pressure is being maintained or identify a potential problem in the system. A detailed discussion of testing of pressure monitors and their use is available in Chapter 10 of NIOSH RI 9701 [NIOSH 2019].

## Filtration and Pressurization Systems

Experience gained from the field studies conducted by NIOSH led to the development of a cab test structure that could be used in controlled laboratory tests to evaluate the different parameters that impact cab effectiveness for reducing dust exposures, including intake and recirculation filter efficiencies. Results from a series of laboratory tests indicated that enclosed cab effectiveness is impacted by intake filter efficiency, air leakage around the intake filter, intake filter loading, recirculation filter usage, and wind infiltration into the cab [NIOSH 2008]. NIOSH subsequently measured the long-term performance of enclosed cabs that were equipped with three filters (intake, recirculation, and final filters) and installed on a face drill and roof bolter at an underground limestone mine. Results from this testing indicated that protection factors greater than 100 were achieved with the three-filter systems on this equipment [Cecala et al. 2012]. A schematic of the three-filter system is shown in Figure 5.1.

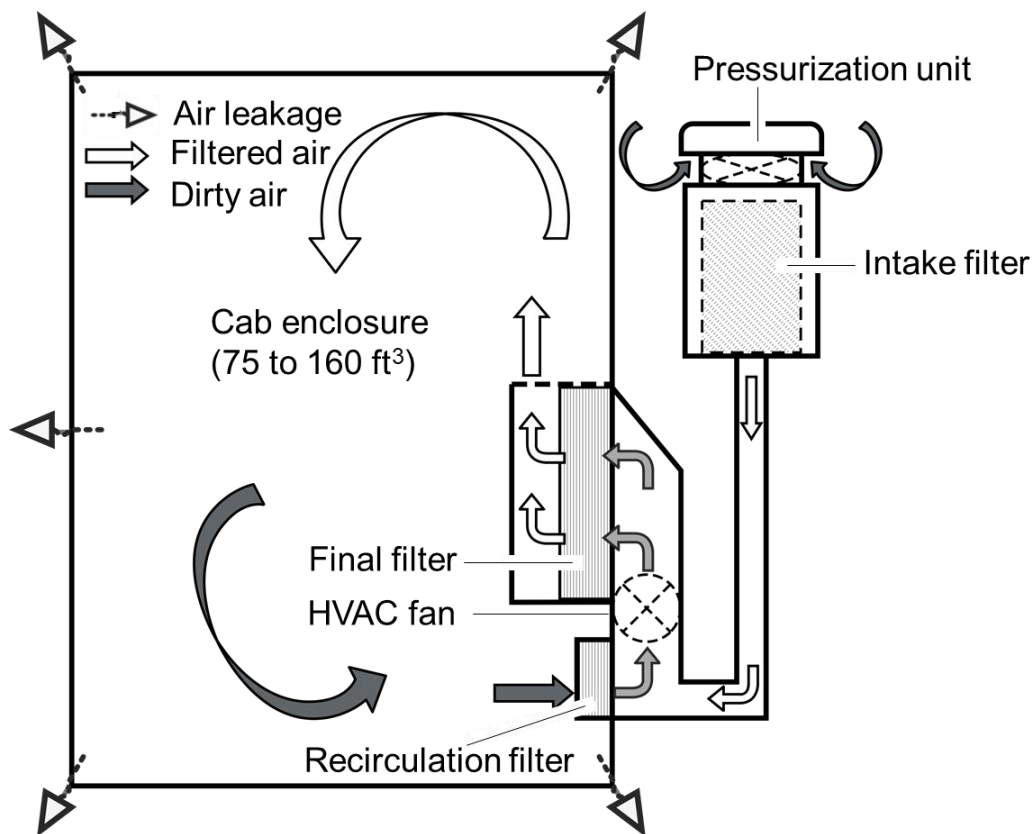

**Figure 5.1. Layout of three-filter system for an enclosed cab field tested by NIOSH.**

The laboratory and field data were used to develop and validate mathematical models that use a node analysis technique to predict system performance. Key model parameters identified for a three-filter system [Organiscak et al. 2014] are graphically illustrated in Figure 5.2.

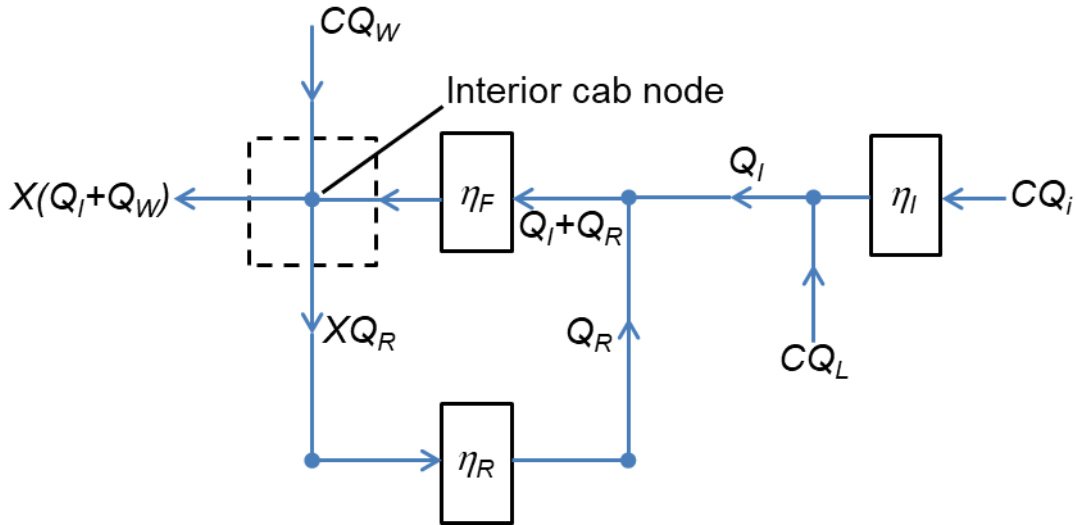

**Figure 5.2. Three-filter (I—intake, R—recirculation, F—final) cab system with Q (I, R, and W—wind, L—leakage, and i—filtered air) denoting air quantities, X (inside cab) and C (outside cab) denoting dust concentrations, and  $\eta$  denoting filter efficiency.**

The mathematical model developed for the three-filter system is shown in Equation 5.1 [Organiscak et al. 2014]. If a system does not have a final filter, a 0 value is inserted for the final filter efficiency, and the model then reduces to a two-filter system. If a system does not have both a final and recirculation filter, inserting 0's for these filter efficiencies reduces the model to a single filter system. Likewise, if no wind infiltration is occurring, a 0 can be inserted for  $Q_W$ , thus eliminating this contamination into the cab concentration. A more comprehensive model that incorporates leakage around the recirculation and final filters was also developed to calculate the impact of leakage around these filters and is discussed in the NIOSH Information Circular 9531 [NIOSH 2018].

$$PF = \frac{C}{X} = \frac{Q_I + Q_R(\eta_R + \eta_F - (\eta_R\eta_F)) + Q_W}{Q_I(1 - \eta_I + (l\eta_I))(1 - \eta_F) + Q_W} \quad (5.1)$$

where: C = outside dust concentration entering the filtration system and cab,  $\text{mg}/\text{m}^3$ ;

X = inside cab dust concentration (interior cab node),  $\text{mg}/\text{m}^3$ ;

$\eta$  = filter reduction efficiency, fractional;

$1 - \eta$  = filter penetration, fractional;

Q = airflow quantity, cfm;

l = intake air leakage, fractional;

with the following filter efficiency and air quantity subscripts:

I = intake;

F = final;

R = recirculation; and

W = wind.

To illustrate how the mathematical model can be used to calculate the protection factor for a filtration and pressurization system, an example calculation is provided with the following parameters: intake and final filters with efficiencies of 95%, recirculation filter efficiency of

75%, cab intake airflow of 50 cfm, recirculation airflow of 200 cfm, a 5% outside air leak around the intake filter, and no wind infiltration. Inserting these values into Equation 5.1 would result in a calculated protection factor of 1,015 as shown below and in Table 5.4.

$$PF = \frac{50 + 200 \times (0.75 + 0.95 - (0.75 \times 0.95)) + 0}{50 \times (1 - 0.95 + (0.05 \times 0.95)) \times (1 - 0.95) + 0} = 1,015$$

Table 5.4 also shows the resulting protection factors for changes in the values of some of the model parameters and illustrates how the performance can be impacted by these changes [NIOSH 2019]. For example, when reducing the recirculation airflow to 100 cfm, the protection factor falls to 610 with all other parameters unchanged. When removing the recirculation filter with the rest of the original conditions unchanged, the protection factor is equal to 985. This change only results in a slight drop from the original PF because the final filter is still in place to capture dust before the air is discharged into the cab. However, because the recirculation filter has a lower efficiency than the final filter, removing the final filter from the system results in a PF of only 41 with all other conditions kept at the original levels. With only a single intake filter utilized, the PF drops to 10. This illustrates how the model can be used to indicate the relative impact on dust levels inside the cab for potential changes to the system.

**Table 5.4. Resulting protection factors for changes in enclosed cab model [NIOSH 2019]**

Intake filter efficiency, %	Recirculation filter efficiency, %	Final filter efficiency, %	Intake air quantity, cfm	Recirculation air quantity, cfm	Protection factor
95	75	95	50	200	1,015
95	No filter	95	50	200	985
95	75	95	50	100	610
95	75	No filter	50	200	41
95	No filter	No filter	50	200	10

As noted in Table 5.3, enclosed cabs that developed 0.1 in. wc of positive pressure or higher resulted in very good PFs and low dust levels in the cab. Positive pressure at this level would prevent outside dust penetration into the cab for a wind velocity of 14.4 miles per hour (mph). Equation 5.2 can be used to quantify the equivalent wind velocity from which a cab is protected for a given positive pressure within the cab [NIOSH 2019].

$$\text{Wind velocity equivalent (mph)} = (4000\sqrt{\Delta p_{cab}}) fpm \times 0.011364 \frac{\text{mph}}{\text{fpm}} \quad (5.2)$$

(@ standard air and temperature and pressure)

where  $\Delta p_{cab}$  = cab static pressure, in. wc; and

where  $fpm$  = feet per minute.

## Filter Selection

The data in Table 5.4 illustrates the positive impact that a second or third filter added to the system can make in reducing dust levels within an enclosed cab. To achieve these improvements, the appropriate filters must be chosen and maintained to sustain consistent dust control within the cab. NIOSH recommends the use of mechanical filters as opposed to electrostatic filters. Mechanical filters become more efficient in capturing respirable dust as the filter becomes coated with a dust cake. However, as the filter loads with dust, the pressure drop across the filter increases which can result in a reduction in airflow through the system.

Filters can be obtained that have different levels of collection efficiency and are typically tested with particles at or greater than 0.3 micrometers ( $\mu\text{m}$ ) in size. High-efficiency particulate air (HEPA) filters are designed to remove at least 99.97% of particles of 0.3  $\mu\text{m}$  in size, with even greater capture of particles larger in size as reported by the Environmental Protection Agency (EPA) [EPA 2020]. Another measure of filter collection efficiency is the minimum efficiency reporting value (MERV), which tests filters for collection efficiency on particles ranging from 0.3 to 10.0  $\mu\text{m}$  in size, encompassing the respirable size range as defined in Table 2.1. The highest-rated filter using this test method is the MERV-16 filter, which is rated with a capture efficiency of 95% or greater for particles in the 0.3- to 10.0- $\mu\text{m}$  size range [NAFA 2020].

Based solely upon collection efficiency, it may be assumed that utilization of HEPA filters in enclosed cab filtration systems would be the obvious choice. However, as was discussed with flooded-bed scrubber performance in Chapter 4, the overall performance of a fan-powered dust collector is determined by a combination of the collection efficiency of the filter media and the amount of air moved through the system. Because of the extremely high collection efficiency of a HEPA filter, the filter media is more restrictive from an airflow perspective. When utilized in mining environments where relatively high dust levels are present when compared to ambient air dust levels typically sampled for EPA requirements, the HEPA filter can load much more quickly and reduce airflow through the system. Also, the increased pressure across the HEPA filter creates a higher potential for airflow leakage around the filter.

In a two-year-long study by NIOSH comparing the performance of HEPA and MERV-16 filters on equipment in an underground limestone mine [Cecala et al. 2016], the HEPA filter had to be changed three times during the study as a result of dust and diesel exhaust loading, leading to decreased intake airflow. During this time period, the MERV-16 filter did not have to be changed as the intake airflow did not drop below a predetermined threshold limit. At the 95-confidence level, there was no statistical difference between the protection factors obtained with the two types of filters. The MERV-16 filters were less restrictive, provided greater cab airflow, required less frequent replacement, and were less expensive than the HEPA filters. Therefore, MERV-16 filters would typically be the preferred choice for use in enclosed operator cabs in mining applications [NIOSH 2019].



## Air Intake and Discharge Locations

As noted in the previous section, dust loading on the filters impacts airflow through the system and the frequency at which filters must be changed. Therefore, it would benefit the long-term performance of filtration and pressurization systems to place the inlet for the intake air in as low a dust zone as possible [NIOSH 2001a]. Typically, this would mean elevating the intake air inlet as high as possible, because the greatest dust generation is typically occurring near ground level for surface mining equipment such as drills, bulldozers, and trucks. For drills, a novel option is to elevate the air inlet to the top of the drill mast [Massey 2017]. Elevated inlets would reduce the amount of dust that needs to be filtered out of the intake air, thus extending filter life and reducing maintenance requirements.

In Chapter 4, using canopy air curtains to provide a filtered airstream down over the breathing zone of an equipment operator was discussed. The opportunity to apply this same principle in an enclosed cab also exists. The filtered air discharge can be located at the top of the cab with the inlet for the recirculation air located at the bottom of the cab [Cecala et al. 2009]. This would result in filtered air moving down over the operator and would thus minimize potential dust exposure from sources inside the cab, which are discussed in the next section.

## Internal Dust Sources

The need to protect mobile equipment operators from respirable dust outside of the enclosed cab is obvious. However, it may not be obvious that dust can be generated inside the cab and expose equipment operators. Three sources of this dust are the dirt/mud that is tracked into the cab on the shoes of the operator, dust-contaminated cloth seats, and dusty work clothes.

When the dirt on the floor is disturbed by operator movement, dust can be entrained into the air, increasing the dust concentration inside the cab. As noted previously, NIOSH has conducted studies of enclosed cabs on multiple types of equipment. A cab on a surface drill was equipped with a heater positioned on the floor of the cab. As NIOSH sampling of this drill extended from the summer into winter, higher dust levels were measured inside the cab. It was found that operation of the floor heater fan was blowing dust from dirt on the floor throughout the cab [NIOSH 2001b]. NIOSH applied a gritless sweeping compound (without sand) to the floor to reduce dust from this source [NIOSH 2001c] but recommends regular cleaning of the cab floor and not using floor-mounted heaters as preferred alternatives to applying sweeping compound.

NIOSH has also observed dust being liberated from cloth seats that have been contaminated with dirt and dust. As the operator sets and moves in the seat, dust can be dispersed from the soiled chair into the air, potentially exposing the operator. Vinyl-covered seats can reduce the dust from this source.

Dust-contaminated work clothes can also be a source of dust liberation as workers move within the cab. The potential impact of dusty clothes along with several references was discussed in the Cleaning the Dust Box section in Chapter 4. A clothes cleaning system has been developed and tested by NIOSH [Cecala et al. 2008; NIOSH 2019] and could be used for cleaning dust from work clothes at surface mining operations.

Utilization of a recirculation and/or final filter in the cab filtration system will more quickly and effectively remove respirable dust that may be generated from sources inside of the cab and further illustrate the value of these filters.

## Dust Control for Highwall Drills

Surface drills can be a large source of dust generation and highwall drill operators have historically been at risk for elevated respirable dust exposure. The greatest source of dust exposure results from dust and drill cuttings being flushed out of the drill hole by compressed air, known as bailing air, which is directed down the drill pipe. This air reaches the bit-rock interface and flushes the broken material up and out of the drilled hole to improve drilling efficiency and speed. Unfortunately, from a dust control perspective, the dust and drill cuttings are discharged from the hole at a high velocity making control of this dust more difficult.

The most common type of dust collection used on surface drills in the U.S. is a dry vacuum collection system. Wet drilling is less popular but another option for controlling dust generation from drilling. Each of these systems has been shown capable of reducing respirable dust levels by over 95% when operating properly [Zimmer and Leuck 1986]. The design and key operating factors for each of these systems will be presented.

### Dry Dust Collection System

A schematic of a typical dry collection system for a surface drill is provided in Figure 5.3. Bailing air flows down the drill pipe and through ports in the drill bit to force dust/cuttings out of the drilled hole through the annular space between the drill pipe and surrounding rock. To improve the capture of this dust by the collector, a shroud is hung from the drill deck to confine the discharged dust. The shroud is typically constructed from conveyor belting which should completely enclose the area under the drill deck area. The most effective shroud will reach from the drill deck to the ground and not have any open seams, thus providing the greatest dust confinement and capture potential for the dust collector. Flexible ductwork transports the captured dust from the enclosed drill deck to the collector. Filter media within the collector removes dust from the airstream with filtered air discharged into the ambient air. The dust captured by the filters is typically removed by compressed air that back-flushes the filters. This dust falls to the bottom of the collector where it is periodically dumped from the collector onto the ground.

The potential sources of dust escaping these dry collector systems include gaps between the shroud and ground, gaps in the shroud itself, gaps between the drill pipe and drill stem bushing, and dust discharging from the collector dump. Controls for each of these locations and the critical importance of dust collector-to-bailing airflow ratio are discussed.

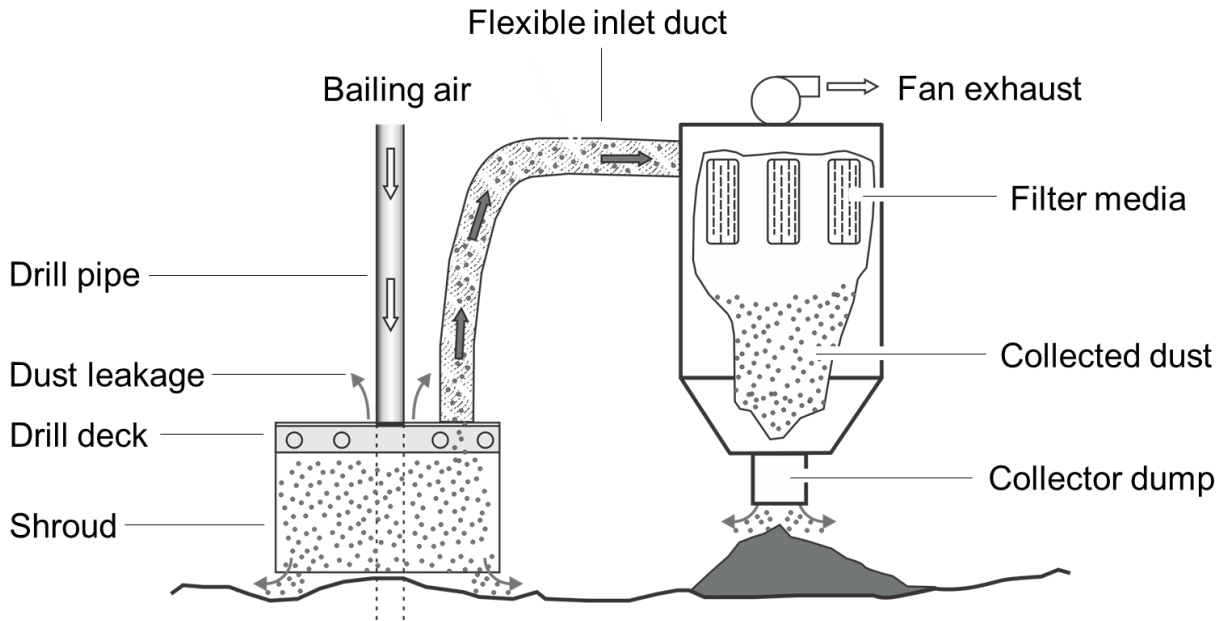

**Figure 5.3. Components of a typical dry dust collection system for a surface drill.**

### *Drill Deck Shroud*

As previously noted, bailing airflow is used to flush dust and cuttings out of the drill hole. The volume of bailing air and the small area of the annulus opening around the drill pipe lead to the bailing air exiting the hole at very high velocities, which can be over 4,500 fpm [NIOSH 2005]. NIOSH research has shown that a significant portion of this high-velocity airstream flows out of the hole up the side of the drill pipe and then flows along the underside of the drill deck and down the inside edge of the shroud where it strikes the ground as shown in Figure 5.4, left [Potts and Reed, 2008]. Dust then escapes the shroud through the gap between the drill shroud and the ground. Likewise, if there are gaps between sections of the shroud, dust can flow through these gaps into the ambient air.

Consequently, a very important part of controlling drill dust is to ensure that a competent shroud is maintained that minimizes the gap between the shroud and ground and has no gaps or tears in the shroud itself. To account for uneven terrain, flexible shrouds that are mechanically raised and lowered can be used to minimize the shroud-to-ground gap height [NIOSH 1998; NIOSH 2005]. The amount of leakage resulting from the height of the shroud-to-ground gap is impacted by the collector-to-bailing airflow ratio and is discussed more completely in that section later in the chapter.

In order to prevent gaps within the shroud, the seams should be overlapped. Most shrouds are rectangular to match the perimeter of the drill deck. A single piece of belting can potentially be installed with the one seam overlapped to avoid a gap in the material. The more common type of shroud has four separate pieces of belting with one piece attached to each side of the drill deck. However, this creates the potential for gaps to form at the corners where two pieces of belting meet as the drill positions on uneven ground in preparation for drilling. One solution to preventing these gaps from occurring is to install corner pieces of belting that are independent of the side-mounted pieces as shown in Figure 5.4, right. These extra pieces of belting help confine the dust within the shroud.

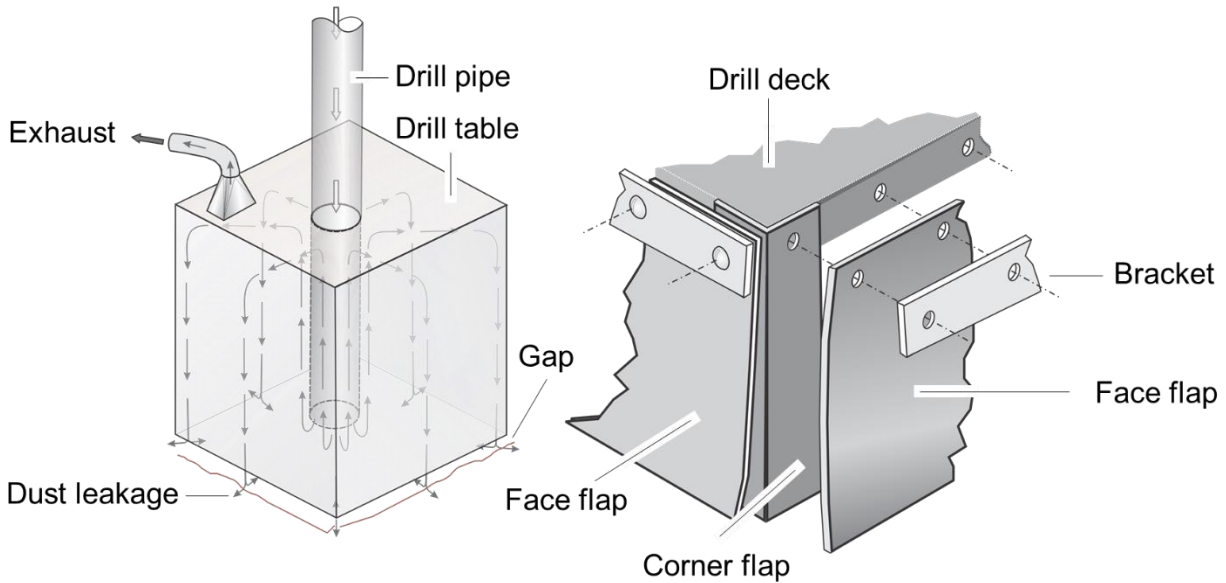

**Figure 5.4. Airflow pattern within drill deck shroud leading to dust leakage (left) and corner flaps added to rectangular deck shroud to reduce dust leakage (right).**

### *Air-blocking Shelf*

As shown in Figure 5.4, left, the airflow pattern formed by the bailing air coming out of the drill hole carries dust down the drill shroud, where it strikes the ground and leaks out through gaps between the shroud and ground. In order to disrupt this airflow pattern, NIOSH developed an air-blocking shelf which is mounted inside the perimeter of the dust shroud [Potts and Reed 2008]. The air-blocking shelf was constructed from 6-inch-wide conveyor belting that was bolted to 2-inch angle iron, which was bolted to the inside perimeter of the shroud. Figure 5.5, left, shows the air-blocking shelf as it was installed on an operating drill for subsequent testing at a mine site. In the lab testing, a collector-to-bailing airflow ratio of 1.9:1 with a shroud-to-ground gap of two inches resulted in the blocking shelf reducing dust levels outside of the shroud by 81%. At a collector-to-bailing airflow ratio of 1.2:1 and a shroud-to-ground gap of eight inches, the dust reduction outside of the shroud fell to 38%. The lab testing also showed that vertical gaps in the shroud above the blocking shelf along with gaps between horizontal sections of the shelf as shown in Figure 5.5, right, resulted in no dust reductions with the air-blocking shelf. These results illustrate how the interaction between components of the dust control system can impact overall performance.

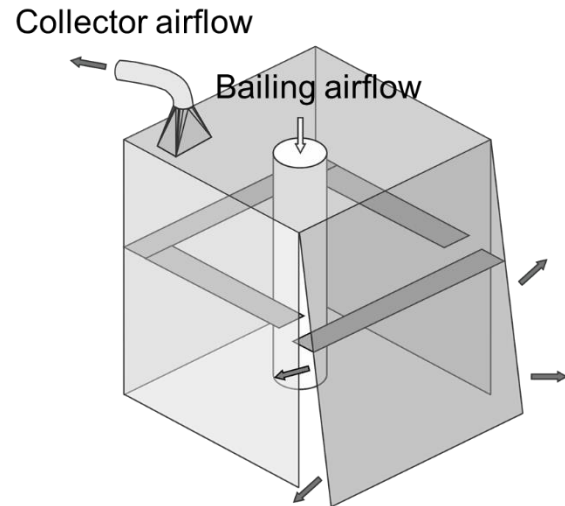

Photo by NIOSH

**Figure 5.5. Air-blocking shelf installed on drill shroud (left) and laboratory test configuration showing leakage through gaps in the drill shroud and blocking shelf (right).**

Subsequent testing of this initial design was conducted at two mines [Potts and Reed 2011]. At Mine A, respirable dust reductions of approximately 70% were measured at sampling locations around the drill. At Mine B, dust levels were much lower in general but a reduction of 81% was measured near the drill shroud. This testing also revealed two operational issues with the original air-blocking shelf design. Dust and drill cuttings had accumulated on the air-blocking shelf during drilling. As the drill mast was lowered, this dust fell from the shelf, releasing dust into the air as shown in Figure 5.6, left. When returning to Mine B four months after initial testing, the air-blocking shelf was still functioning but the angle iron had been bent through impact between the shroud and rock piles on the bench.

To address these issues, NIOSH redesigned the shelf so that it was constructed of 8-inch-wide high-density polyethylene (HDPE), was constructed as multiple overlapping pieces as opposed to long continuous pieces, and so that the pieces were mounted at a 45-degree angle as shown in Figure 5.6, right. The HDPE material has a slippery surface which reduces dust buildup, while the use of shorter sections reduce possible damage during tramming. Chains were added to help hold the shorter pieces at the desired 45-degree angle when the mast is in its drilling position. In the initial laboratory testing previously discussed [Potts and Reed 2008], testing that simulated the shroud mounted at a similar angle resulted in dust reductions only slightly lower than the original design (76% versus 81%). Therefore, angling the air-blocking shelf did not substantially impact dust control performance.





Photos by NIOSH

**Figure 5.6. Dust released when material drops off of air-blocking shelf (left) and modified design with short, overlapping sections supported by chains to maintain the 45-degree angle (right).**

### *Drill Stem Bushing*

The drill pipe extends with relatively tight clearance through a bushing mounted to the drill deck. This bushing helps to guide the drill pipe, can help dampen vibration, and provides a wear surface. As the bushing wears, the gap between the drill pipe and bushing increases. As noted previously, high-velocity bailing air is exiting the drill hole and flowing along the outside of the drill pipe to the underside of the drill deck. As the gap in the bushing increases, dust can be blown up through the bushing into the ambient air as shown in Figure 5.7. It is important to monitor the wear of the bushing and replace it as the wear becomes excessive.



Photos by NIOSH

**Figure 5.7. Dust leakage through drill stem bushing on two different drills.**

One method of reducing dust release through the bushing is to install a rubber shield under the drill deck as shown in Figure 5.5, left, to deflect material that would normally reach the bushing. Typically, conveyor belting is used with a round hole cut in the center of a piece of conveyor belting. Since the belting is flexible, it can have a tighter fit with the drill pipe to minimize the

amount of material bypassing it. However, because of the tighter fit, the conveyor belting is subject to quicker wear and must be replaced periodically.

A non-contact option for reducing leakage through the drill stem bushing is the application of an air ring seal that was developed through U.S. Bureau of Mines (USBM) research [Page 1991]. This technology used a circular steel ring that was mounted to the underside of the drill deck and was just large enough so that the drill bit and pipe passed through the center of the ring. Compressed air from the drill's compressor was supplied to the air ring and dispersed through a series of 1/16-inch-diameter holes that were spaced roughly 1/2-inch apart around the inside perimeter of the air ring as shown in Figure 5.8. High-velocity air jets exited the holes in the ring at a 45-degree angle toward the drill pipe to prevent cuttings and respirable dust from passing through to the drill stem bushing. When tested at an air pressure of 30 pounds per square inch (psi), the air ring was successful in reducing respirable dust levels and material deposition on top of the drill deck. For current applications, the amount of air available for the air ring seal will be dependent upon the drill and the capacity of its compressor.

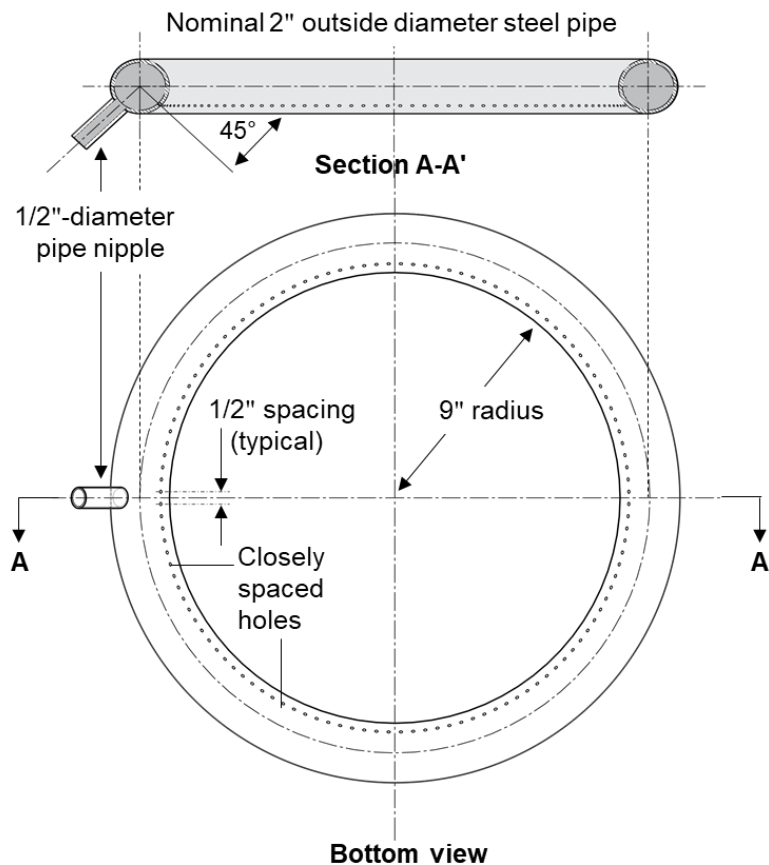

**Figure 5.8. Air ring seal designed to reduce leakage through drill stem bushing.**

### *Dust Collector Dump*

When the accumulated dust inside the dust collector is discharged from the collector dump, it typically must fall 2–3 feet through the air before striking the ground, allowing respirable dust to

disperse into the air. Obviously, dust composition, drop distance, wind speed, and wind direction will impact potential respirable dust entrainment and worker exposure.

A simple solution for reducing respirable dust entrainment during this process, which occurs repeatedly throughout a shift, is to create a “sock” or shroud that encloses the dust as it falls and reaches the ground. A section of brattice cloth can be attached to the dump discharge with a large hose clamp with the length of brattice long enough so that it touches the ground. The brattice should overlap itself to provide a competent seal and allow for expansion of the brattice as material builds at the ground level. Figure 5.9, left, illustrates a dust plume released during an unconfined dump and with brattice installed on the drill collector dump (Figure 5.9, right). Sampling within 2–3 feet downwind of the collector dump resulted in average respirable dust levels being reduced by nearly 80%, dropping from 0.92 mg/m<sup>3</sup> to 0.20 mg/m<sup>3</sup> [Reed et al. 2004].



Photos by NIOSH

**Figure 5.9. Dust at collector dump before (left) and after shroud installation (right).**

### *Collector-to-bailing Airflow Ratio*

Dust collector airflow is the quantity of air pulled from within the drill shroud by the fan of the dust collector. Bailing airflow is the quantity of air used to flush cuttings out of the drill hole, which is determined by the capacity of the air compressor installed by the manufacturer. The ratio between the dust collector airflow and the bailing airflow (collector airflow, cfm ÷ bailing airflow, cfm) is a key operating parameter for controlling respirable dust liberation at the drill deck.

A 1:1 ratio would indicate that these two airflows are balanced with equal quantities of air flowing into the shrouded drill deck and being pulled out to the collector. However, the preferred operating condition is to have the collector airflow be greater than the bailing airflow. In this operating state, air from outside of the drill shroud needs to flow into the shroud to meet the collector airflow demand. This airflow pattern would create negative pressure within the shroud and assist in keeping drilling dust from escaping through gaps in the shroud.

NIOSH has conducted research investigating the relationship between the collector-to-bailing airflow ratio and the height of the gap between the shroud and ground. As shown in Figure 5.10, optimum drill dust control was obtained with higher collector-to-bailing airflow ratios in combination with minimized shroud gap heights [Organiscak and Page 2005]. For increases in the collector-to-bailing airflow ratio, the largest dust reduction was observed when going from a 2:1 ratio to 3:1. This data also shows that as the shroud gap heights increased from 2 inches to 14 inches, substantial increases in dust outside of the shroud occurred, even at the maximum tested collector-to-bailing airflow ratio of 4:1.

This data suggests that mine operators should strive to achieve a collector-to-bailing airflow ratio of 3:1, while keeping the shroud gap height as close to 2 inches as possible. Unfortunately, 2:1 ratios were typical of drills found by NIOSH at mines [Page and Organiscak 2004], with poorly operating drills having ratios of 1:1 or lower.

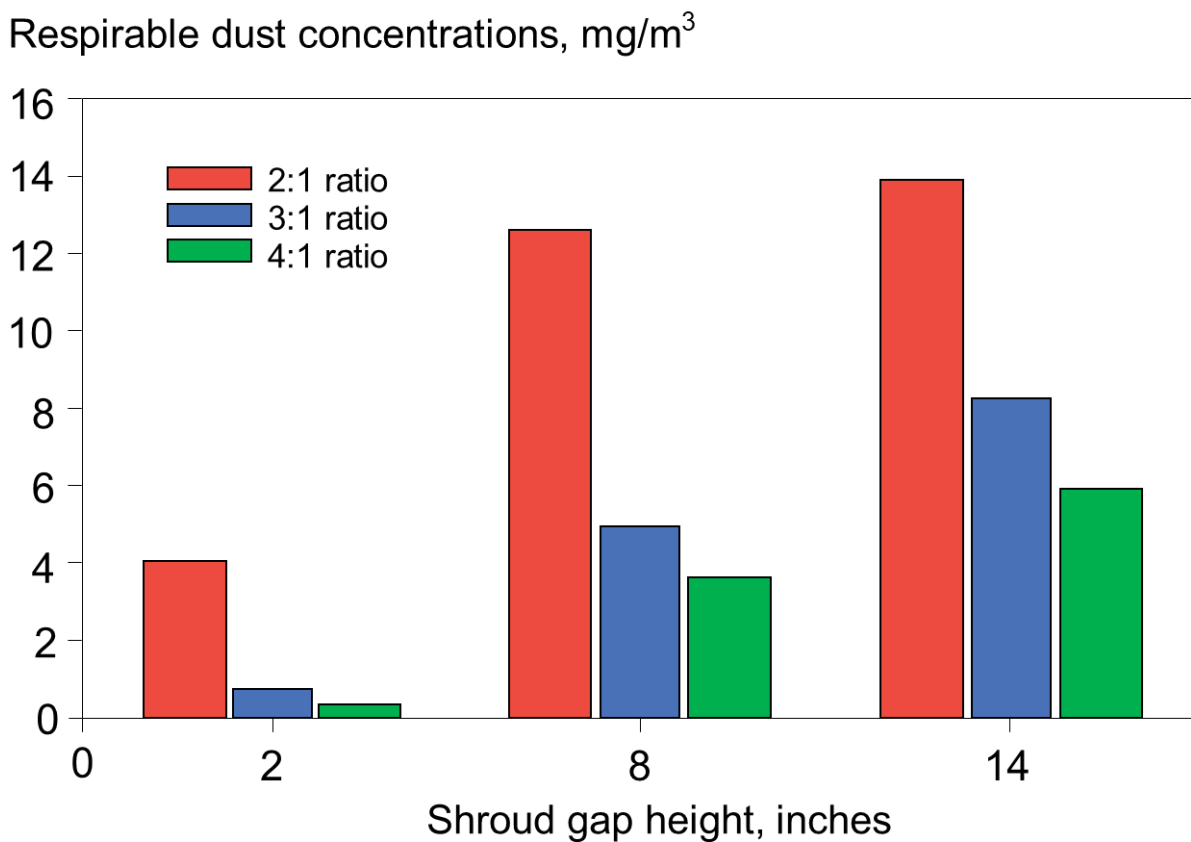

**Figure 5.10. Impact on dust levels outside of the drill shroud when changing the collector-to-bailing airflow ratio and drill shroud gap height.**

The data in Figure 5.10 illustrates the importance of maintaining the desired dust collector-to-bailing airflow ratio and a competent, properly positioned dust shroud. Typically, the bailing airflow is fairly consistent as long as the compressor is operating properly. However, several factors can impact the dust collector airflow and should be checked periodically to ensure proper operation:

- the collector inlet and tubing are free of obstruction,
- the intake duct and collector housing are tightly sealed and free of leaks,
- the dust collector filters are not damaged and are changed at recommended intervals,
- the collector filters are being backflushed properly and at specified intervals, and
- the collector fan is operating properly and to specification.

## Wet Drilling

Injecting water into the bailing air can be successful in reducing dust liberated by drilling at surface mines. After being injected through the drill pipe column to the bit, air and water droplets flush the cuttings and dust from the hole through the annular space between the drill pipe and surrounding rock. As the water and dust travel up the drill hole, particles are wetted by the water droplets, thus increasing drop-out when the airstream exits the hole. Dust reductions up to 96% were observed in research funded by the USBM [Zimmer et al. 1987]. However, there are several operational issues that must be addressed when using wet drilling, including the need to monitor and control water flow rate, the need to periodically fill the on-board water tank and protect against freezing in cold weather, and the need to protect tri-cone rotary drill bits from the injected water.

The amount of water added to the bailing air is critical from dust control and operational perspectives. Sufficient water must be added to effectively control generated dust, but too much water can lead to problems with flushing the cutting from the hole, drill pipe binding, increased bit wear, and hole degradation, depending upon the strata being drilled. At one mine, changing the water flow rate from approximately 0.2 gallons per minute (gpm) to 0.8 gpm for drills from two different manufacturers increased the average dust control for these drills from 24% to 91% [Zimmer and Lueck 1986]. A point of diminishing return in dust control efficiency for increasing water flow was observed at 0.6 gpm for one drill and 0.8 gpm for the second drill. This data illustrates the need to determine the optimum water flow rate for individual drills and also for changes in overburden composition.

The drill operator can manually adjust the water flow rate, and it has been recommended that water flow is slowly increased until visible dust emissions abate [NIOSH 2003]. It should be noted that a several-second delay between adjusting the water flow valve and the impact on dust emissions is present. This delay should be taken into account when adjusting water flow to prevent over-adjusting.

For wet drilling, a water pump injects water from a tank located on the drill into the bailing airflow. Although high water flow rates typically are not required as mentioned above, the water tank must periodically be refilled, typically from a water truck. Also, in regions where freezing temperatures occur, efforts must be made to prevent the water from freezing either through heating or the use of an anti-freeze additive.

## Water Separator Sub

The useful life of tri-cone bits can be shortened by 50% when wet drilling due to rapid degradation of drill bit bearings by hydrogen embrittlement and accelerated bit wear as a result of operating in the abrasive rock-water slurry environment at the drilling interface [USBM 1988]. To prevent this problem, the water injected into the bailing air must not reach the tri-cone bit, which is accomplished through the implementation of a water separator sub inserted



into the drill string. The sub is a short section of the drill column assembly that is placed between the drill pipe and drill bit.

Within the interior of the water separator sub, the water-laden bailing air is forced to make sharp turns before reaching the drill bit. The bailing air is capable of making these turns but the water droplets cannot because of their inertia and are separated out of the airstream. The positive pressure within the drill pipe created by the bailing air then forces the accumulated water out of weep holes in the walls of the separator sub (Figure 5.11, left). Although the water separator sub does not separate 100% of the water, a slight mist/fog is discharged through the bit with the majority of water being discharged through the weep holes (Figure 5.11, right). The water can then mix with the drill cuttings as they are transported out of the hole by the bailing air. Due to the internal space requirements for components in this original design of a water separator sub, it could only be used for drilling holes 10 inches in diameter or greater. Subsequently, an alternative water separator sub that uses centrifugal force to separate the water from the air was designed and could be used to drill holes as small as 6.625 inches in diameter [Listak and Reed 2007].

Tests results from three studies with a water separator installed showed the following:

- no difference in average dust levels when comparing wet drilling with and without the water separator installed [USBM 1988].
- up to a 25% reduction in average dust levels when comparing wet drilling with and without the water separator installed on a drill in Australia [Millgate and Hagan 2015].
- a substantial reduction in maximum dust levels observed when comparing wet drilling with the water separator sub to a dry collection system [Listak and Reed 2007].

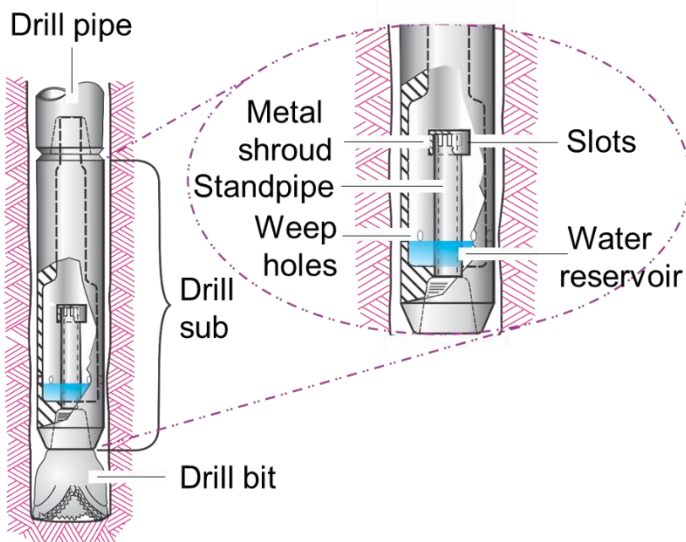

Photo by NIOSH

**Figure 5.11. Schematic showing internal components of water separator sub (left) and water being discharged through weep holes (right).**

In the USBM study, multi-year data on bit life was analyzed and indicated that use of the water separator sub increased average bit life from approximately 2,000 ft/bit to 9,000 ft/bit. In the Australian study, average bit life over a multi-month test period was increased by 58% when using the water separator sub. Therefore, the use of a water separator sub can increase bit life when compared to conventional wet drilling with no adverse impact on or even an improvement in respirable dust control.

## Haul Road Dust Control

Dust generated by equipment traveling over haul roads at surface mines can be a major source of dust emissions as shown in Figure 5.12, left, which can pose both health and safety concerns. If the generated dust contains quartz, truck driver operators and workers in the vicinity of the haul roads can be exposed. Depending upon the severity of dust generated on haul roads, visibility can become a safety concern as shown in Figure 5.12, right. The level of dust generation from haul roads is dependent upon the quality of the haul roads, the traffic traveling the haul roads, dust controls being used, and weather conditions. Each of these items is discussed.



Photos by NIOSH

**Figure 5.12. Examples of haul road dust generated by haul trucks. In the photo on the right, the green box outlines a pickup truck and illustrates the loss of visibility from dust obstruction.**

## Road Construction

When a vehicle travels on a haul road, the wheels exert compression and tension forces on the road surface. These forces can readily degrade roads constructed from weak materials, producing fine particles that can be entrained into the ambient air by equipment movement along the road. Alternatively, haul roads constructed of the proper materials degrade less rapidly, lessening the dust emission potential of the road. Although a properly constructed road has a higher initial cost, it requires less road maintenance over the same period of use and reduces equipment maintenance costs, including increased tire life.

Because haul roads at mines can be subjected to large-capacity vehicles (up to 400 tons), proper design and construction of these roads, including selection of appropriate materials, can have a significant impact on long-term road performance. A properly designed road will consist of a subgrade, a subbase, and a wearing surface constructed to recommended specifications. More detailed guidance for designing each of these road layers and an example of the associated calculations are provided in Chapter 11 of NIOSH RI 9701 [NIOSH 2019].

Because the wearing surface layer of the road has direct contact with the mining vehicles, the materials used in constructing this layer should possess certain physical properties: resistance to wear, soundness, maximum size, particle shape, and gradation [Midwest Research Institute 1981].

- A high *resistance to wear* indicates that the material will not easily disintegrate under the anticipated traffic load. Materials such as limestone or granite are desired as opposed to softer materials such as coal, shale, or vermiculite.
- *Soundness* is the ability of the material to withstand the region's climatic conditions (precipitation and temperature changes) and the material's ability to not easily be broken down from natural weathering processes.
- Generally, the *maximum size* of the aggregate to be used for the surface of the road is 1 inch, to facilitate maintenance with a road grader.
- Material that contains angular *particle shapes* with rough surfaces promotes the stability, density, and durability of the road.
- Road material containing a good representation of particle size fractions from large to small have a desirable *gradation* or size distribution.

In addition to haul roads, surface mines can have access roads that are used to transport personnel and supplies. Typically, the vehicles using access roads are lower in weight and traveling less frequently than production haul trucks. However, due to the dynamic nature of mining, these access roads may at times be used as haul roads and can be designed to haul road specifications. Otherwise, information for designing smaller access roads can be found in *Gravel Roads: Maintenance and Design Manual* [Skorseth and Selim 2000].

## Traffic Control

Although a properly constructed haul road can be effective in reducing dust generation, there are additional administrative controls that can further assist in controlling dust emitted from haul road use. These administrative controls include vehicle speed and traffic flow.

### Vehicle Speed

A majority of the fugitive dust from haul roads is generated through the forces of the wheels on the road surface and by the turbulence created by the vehicles [Moosmüller et al. 2005]. As the speed of haul trucks increases, the amount of turbulence and dust liberation also increases, as shown in Figure 5.13 [Thompson and Visser 2001]. In one study, reducing vehicle speed from 25 to 10 mph reduced the generation of dust particles < 10 µm by approximately 58%, and by 42% when speeds were reduced from 25 to 15 mph [Watson et al. 1996].

In another study, limiting speeds on unpaved roads to 25 mph reduced dust levels by 44% [Countess Environmental 2006]. Although reducing the speed of vehicles traveling on haul roads can be an effective method for dust control, these actions may impact the production rate of the mine.

### Traffic Flow

If haul trucks travel in close proximity to one another on unpaved roads, the dust plume created by the leading truck can engulf the trailing truck and expose this driver to elevated dust levels.

One study showed that maintaining a 20-second following distance between haul trucks resulted in up to a 52% reduction of respirable dust exposure to the trailing truck driver [Reed and Organiscak 2005]. Also, the dust cloud generated from the lead truck can impair the visibility of the trailing driver, but the 20-second or greater time interval between trucks can allow this dust to dissipate.

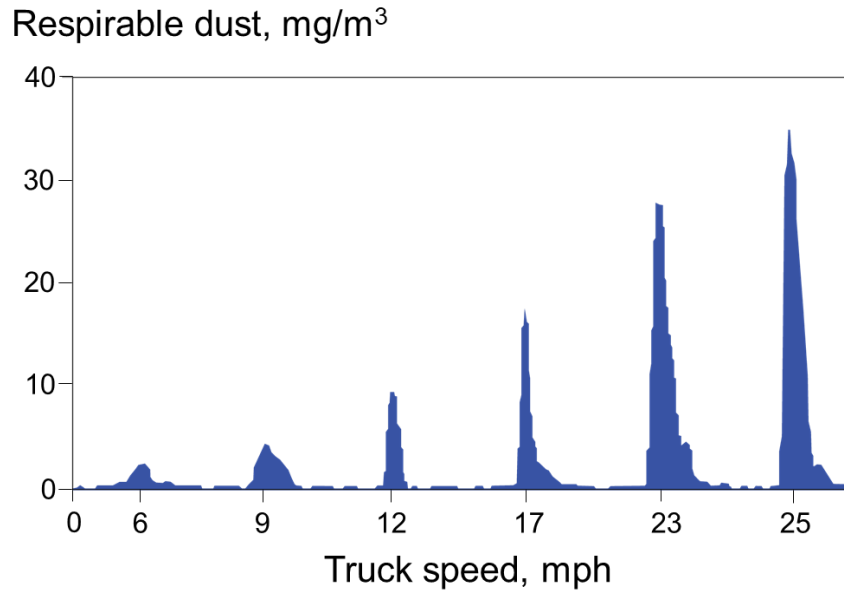

**Figure 5.13. Graph showing dust levels measured at the roadside for a haul truck traveling at various speeds [adapted from Thompson and Visser 2001].**

Additionally, the proper use and maintenance of filtration and pressurization systems on enclosed cabs of haul trucks are important for controlling the respirable dust exposure of truck operators. Therefore, the information on enclosed cabs provided earlier in this chapter should be used to maximize the protection afforded to haul truck drivers.

### Water Application

Watering roads with a water truck is the most common method used for haul road dust control. Water trucks consist of a tank capable of holding up to 90,000 gallons, a water pump, and plumbing designed to deliver water to spray nozzles mounted at the rear of the truck. The nozzle spray pattern and layout are typically designed to wet at least one lane of a haul road in one pass as shown in Figure 5.14. Although watering requires no road preparation prior to application, it must be reapplied on a consistent basis. Additionally, the dust control efficiency for water can be highly variable because it depends on road material type, traffic, and weather conditions.





Photos by Mega Corporation

**Figure 5.14. Water trucks wetting haul roads with rear-mounted water sprays (left) and a water distribution manifold (right).**

The nozzles used for watering roadways generally have fan spray patterns and are mounted on the truck in a stationary position. Various types of fan spray nozzles are fabricated by different manufacturers with examples shown in Figure 5.15. Alternatively, water can be applied through water distribution manifolds. Simple manifolds can be constructed by drilling holes along the bottom of a pipe that is then mounted on the back of the water truck as shown in Figure 5.14, right. Cutting horizontal slots in water stand-pipes (or endcaps) at the corners of the water truck can expand coverage. To achieve optimal spray coverage, it is best to orient the nozzles in a manner to minimize overlap of the water spray from other nozzles [James and Piechota 2008]. It is also important that the water reaches the desired target location and is not blown away by the ambient wind. As a result, lower water pressures, 15 psi or less, that produce larger-sized water droplets are often utilized [Franta 2016].



Photo by Access Truck Parts

Photo by Access Truck Parts

Photos by Spraying Systems Co.

**Figure 5.15. Various types of manufactured spray nozzles (not to scale) used to water roadways.**

There are no universal guidelines for the amount of water to use for dust control on haul roads nor for determining optimum haul road watering intervals. The quantity of water sprayed onto the road during each application, the composition and layout of the road, the traffic volume on the road, and the prevailing weather conditions are factors that should be used to determine site specific optimum intervals for watering [Cowherd et al. 1988]. Water application rates ranging from 0.02 to 0.50 gallons per yard squared (gal/yd<sup>2</sup>) have been utilized at surface mining operations in various countries [Bulger 2015; Midwest Research Institute 1981; Tannant and Regensburg 2001]. Figure 5.16 illustrates the importance of keeping the road wet at one operation as airborne respirable dust levels increased substantially as the road dried out after being watered at 10:00.



Regular light watering may be more effective for dust control than infrequent heavy watering and also reduces the potential hazards resulting from excess water (e.g., slick ramps, degradation of roadway) [Thompson and Visser 2007; Bolander and Yamada 1999]. Utilization of speed-sensitive watering systems can assist with the uniform application of water on haul roads. These systems adjust the quantity of water that is discharged onto the road in relation to the travel speed of the watering truck [Bulger 2015]. Another technique that has been recommended to reduce the potential of tire slippage, particularly critical on ramps, is intermittent or spot watering, which results in alternate wet and dry sections of roadway [Bennink 2007; Thompson 2020].

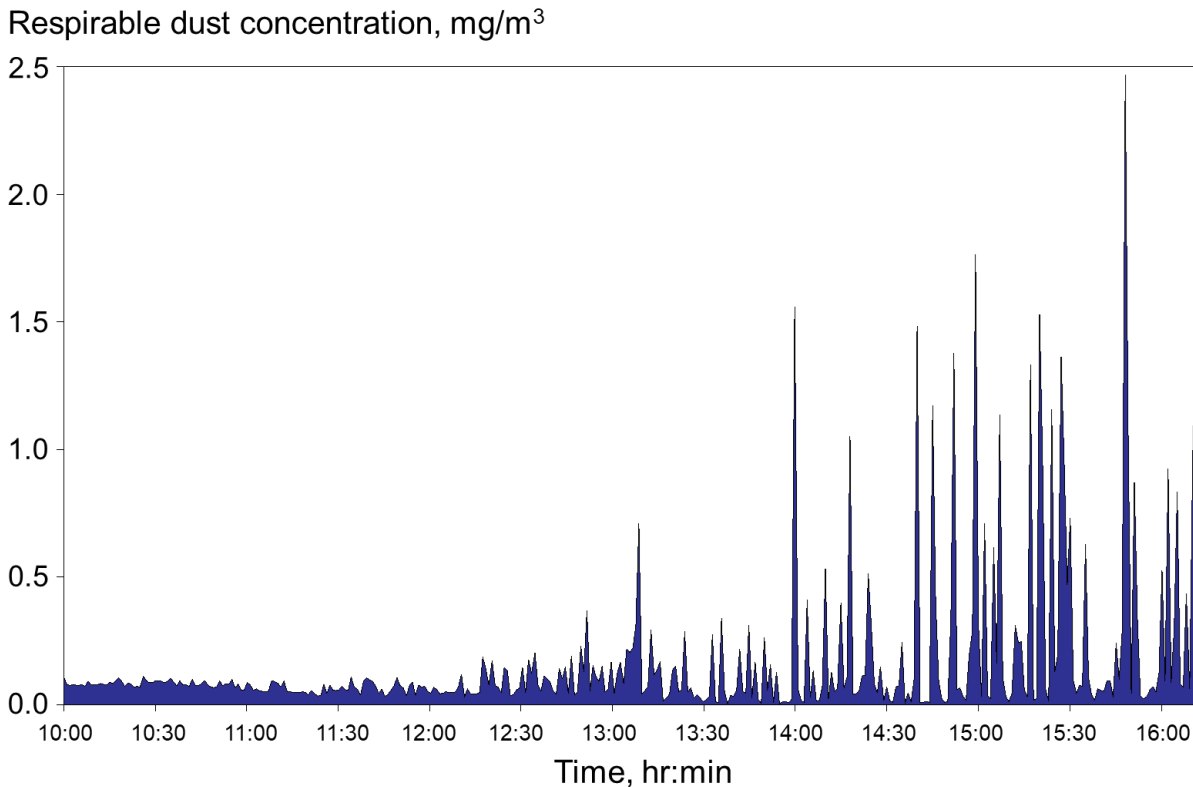

**Figure 5.16. Graph showing respirable dust concentrations measured along a haul road after water application occurred at 10:00 [from Organiscak and Reed 2004].**

### Chemical Dust Suppressants

A number of different chemicals, including salts, petroleum emulsions, polymers, and adhesives, are available for suppressing dust on haul roads. Each of these dust suppressants has specific application methods, but the haul road should be conditioned prior to the suppressant being applied. In general, the haul road surface should be prepared by the following:

- eliminating potholes and road corrugations through backfilling and blading as necessary,
- blading large material not suitable as a good road surface off the road, and
- establishing a crown on the road to eliminate standing water that leads to potholes and road degradation.

The manufacturer's instructions should then be followed for applying a specific suppressant in order to obtain optimum performance. A brief description of each type of suppressant will be provided.

### *Salts*

Salt solutions are commonly mixed with water to reduce haul road dust. Magnesium chloride and calcium chloride are the most common salt-based dust control agents. Advantages of using salt-based agents for dust control are that they absorb moisture from the atmosphere to maintain the road's moisture content at a higher-than-normal level, generally do not require time to cure after application, and can thaw snow and ice during winter. Conversely, chlorides may cause corrosion sooner than normal on equipment using the treated roads. They can also be harmful to vegetation and to personnel if skin or eye contact occurs. Chlorides are also water soluble and may leach from the road surface during precipitation, thereby degrading performance over time [Midwest Research Institute 1981].

### *Petroleum Emulsions*

Petroleum resins are engineered products or byproducts of lubrication oil manufacturing. They generally consist of stable emulsions of petroleum residuals, solvent extracts, and acid sludge. Haul roads have been reported to be relatively dust free for a period of three to four weeks when using petroleum emulsions [Midwest Research Institute 1981]. A primary advantage to using petroleum emulsions is that they are not corrosive. They are also not water soluble, are relatively nontoxic and nonflammable, and do not have adverse effects on plant growth (for revegetation needs). However, most resins require a 24-hour cure time after application and traffic should be limited to wheeled equipment only to prevent breakdown of the treated surface. Also, storage temperatures of the emulsion products prior to application must be controlled as they cannot endure freezing or boiling conditions.

### *Polymers*

Polymers include acrylics and vinyls, which are chemical additives mixed with water to form a diluted solution and then applied to the road surface topically. Polymers are generally noncorrosive and nontoxic, and they can be utilized for soil stabilization. As a dust control agent, they are also generally long lasting, although it has been shown that precipitation can affect longevity.

### *Adhesives*

Adhesives are compounds and solutions that are mixed with the soil surface to form a new road surface. One of the most common and well-established dust control adhesives is lignin sulfonate, a waste product from the paper/pulp industry that is created when wood chips are placed in a sulfonate solution. This adhesive is noncorrosive and is easily obtainable due to the large size of the paper/pulp mill industry. Heavily traveled haul roads have been observed to be kept dust free for periods of three to four weeks. However, lignin sulfonate can interfere with some mineral processing processes, such as flotation, and since it is water soluble it can be washed away from the road surface, requiring reapplication to maintain proper dust control [Midwest Research Institute 1981].

Multiple factors can impact the dust control efficiency of the haul road applications, discussed above, including road composition, application concentration, attention to application instructions, traffic type and frequency, and weather conditions. As a result, a range of control efficiencies have been reported and are summarized in Table 5.5.

## Dust Control at the Primary Dump

At surface mines, the coal is typically loaded into haul trucks in the pit and transported to a dump location, which is either a primary hopper or a stockpile. If unloaded to a stockpile, the coal is subsequently transported by a front-end loader to the primary hopper. When the coal is unloaded at the hopper, the coal flowing into the hopper quickly displaces an equivalent volume of air which will carry dust with it as it billows out of the hopper. This dust-laden air can expose the haul truck or front-end loader operator to elevated dust levels if their vehicle is not equipped with an effective enclosed cab filtration system as discussed earlier in this chapter. Other mine personnel, such as crusher operators or maintenance staff, working in the vicinity of the primary dump can also be exposed. Therefore, technologies that are used to control dust liberation at the primary hopper are discussed.

**Table 5.5. Summary of control efficiencies for haul road dust suppressants**

Control type	Efficiency, %	Application frequency	Reference
Water	95	0.5 hours	EPA 1998
	74	3–4 hours	EPA 1998
	40	1 hour	USBM 1983
	55	0.5 hours	USBM 1983
Salt-magnesium chloride	95	22 days	USBM 1987
Salt-calcium chloride	82	2 weeks	USBM 1983
	14	7 weeks	USBM 1983
Petroleum emulsion	70	21 days	USBM 1987
	4–38	4 weeks	USBM 1983
Polymer	74–81	< 4 weeks	USBM 1983
	3–14	> 5 weeks	USBM 1983
	94–100	< 1 week	Gillies et al. 1999
	37–65	11 months	Gillies et al. 1999
Adhesive	50–63	< 4 weeks	USBM 1983

## Enclosure of the Primary Dump

Walls can be constructed around the primary dump location to form an enclosure that should be custom-designed to accommodate the dump vehicles being used. Walls should be physically robust, tight fitting, and designed with proper access for maintenance. Staging curtains, also called stilling curtains, can be hung in the enclosure to provide physical barriers that break up the

natural airflow patterns that are created when a large volume of product is dumped into the enclosure causing dust to billow out of the primary dump as shown in Figure 5.17 [Weakley 2000].

Another option to restrict the dust from escaping the enclosure is installing panels of flexible plastic stripping at the dump side of the enclosure as shown in Figure 5.18. This plastic stripping should contain overlapping sections to provide a flexible seal that resists damage if contacted by the bucket of the front-end loader or the bed of the haul truck during dumping.

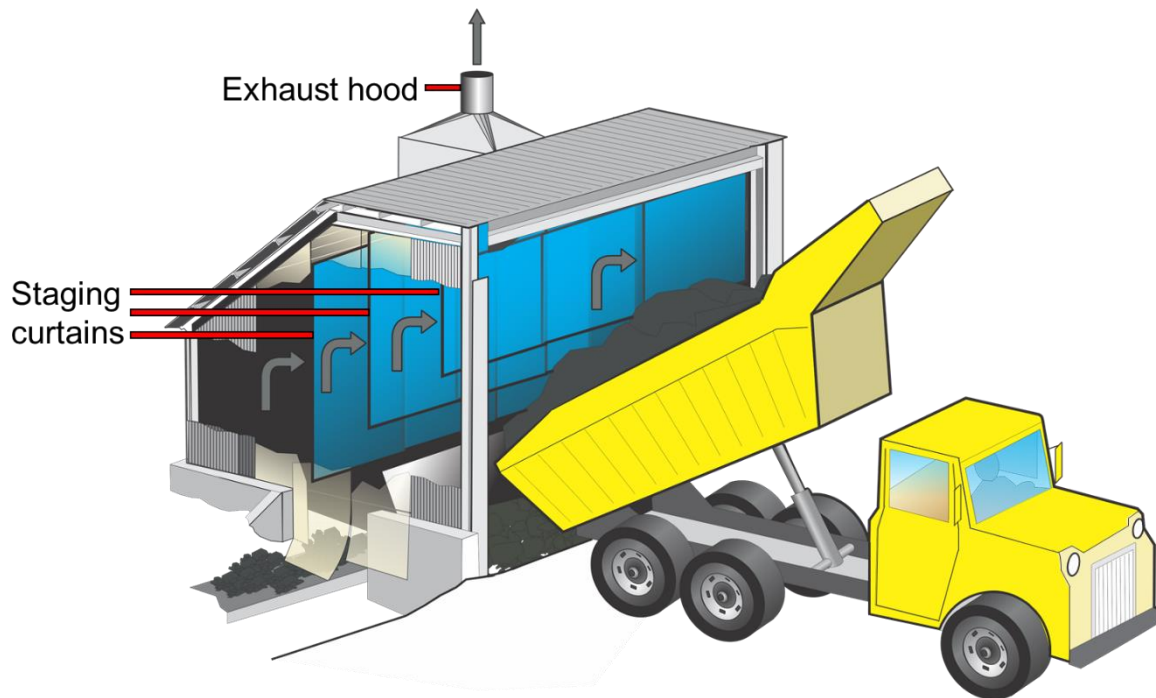

**Figure 5.17. Staging curtains and local exhaust ventilation for controlling dust liberation at a primary dump.**

Finally, a local exhaust ventilation system can be installed to capture and filter the dust-laden air from the enclosed dump area as shown in Figure 5.17. This would be most appropriate when the primary dump is at a location where the dust could enter an adjoining structure or frequently impact workers outside of the dump. Since primary dumps are usually large, the area of any openings in the enclosure should be minimized to avoid dust escape. Typically, a significant amount of exhaust airflow would be required to create a negative pressure to induce air movement into the enclosure. The following equation can be used to estimate the initial exhaust airflow needed to account for the quantity of air displaced by dumping:

$$Q_E = 33.3 \times (600T \div G)$$

where  $Q_E$  = exhaust air volume, cubic feet per minute;

$T$  = weight of material dumped, tons per minute; and

$G$  = bulk density of material, pounds per cubic foot.

Additional design criteria for using exhaust ventilation are provided in Chapter 5 of NIOSH RI 9701 [NIOSH 2019].

## Water Sprays at the Primary Dump

Water sprays can be installed in the primary dump enclosure to assist in controlling dust during coal dumping. Sprays can be directed at the coal product to wet the material in order to suppress dust before it gets airborne. Full cone sprays would be an appropriate choice for wetting and could be placed on both sides of the coal stream as it is unloaded. Figure 5.18 shows sprays mounted at the bucket of the front-end loader and on the enclosure side of the tire stop that are directed at the product stream. The water sprays in the tire stop help prevent dust from rolling back under the dumping point, while the tire stop provides a physical barrier to prevent rollback. Because the tire stop sprays are in a vulnerable location, they should be recessed into the tire stop or shielding should be provided to offer protection for the nozzles.

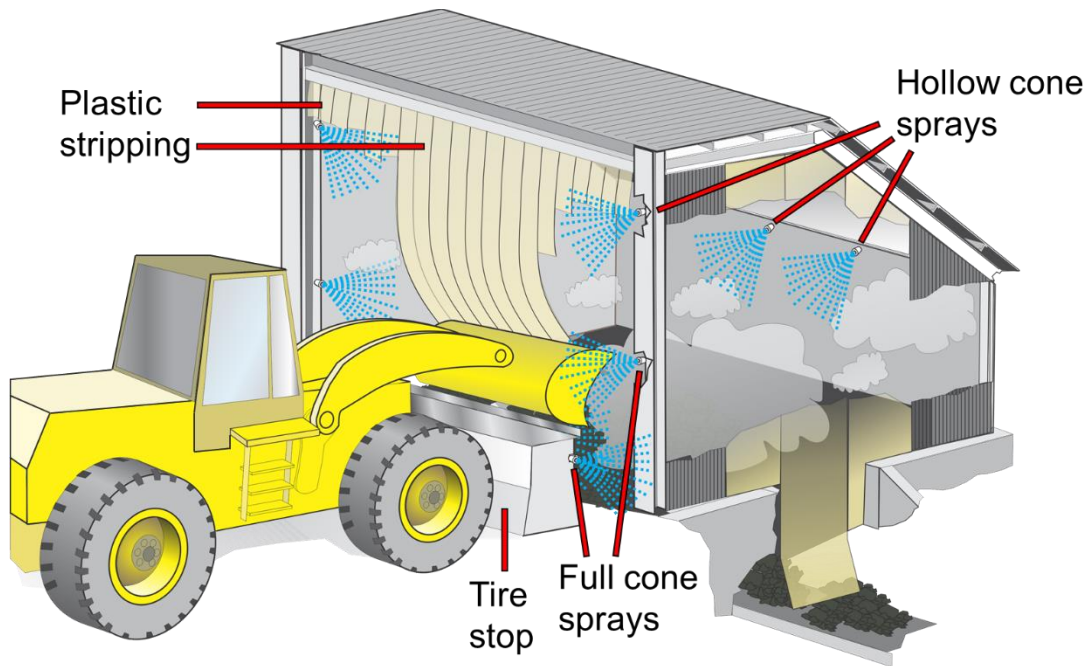

**Figure 5.18. Illustration of a primary dump with full cone water sprays used for wetting while hollow cone sprays are used for airborne dust capture.**

Hollow cone sprays could also be installed in elevated positions in the enclosure to capture dust as it becomes airborne. Figure 5.18 illustrates potential locations for these sprays which should be oriented into the enclosure so that airflow induced by the sprays is directed inward.

## Activation of Dust Controls

Because vehicle presence at the primary dump can occur intermittently, it may be appropriate to have the water sprays and exhaust ventilation system only operate when a vehicle is unloading. A photo cell sensor or mechanical switching device can be used to activate the installed controls. The controls can be programmed to continue to operate for a set period of time after the vehicle has completed dumping to further reduce dust that may still be present in the enclosure. Utilization of an activated system will help to conserve resources and prevent operational problems that may result from continuous water application.



## **Stockpile and Preparation Plant Dust Control**

The primary focus of this handbook is to identify dust control technologies that can be applied during the extraction and transport of coal from the face to the processing area. No technologies have been discussed that address potential dust control issues for coal storage, processing, or shipment. However, information on dust controls for these sources is available as noted below.

Airborne dust can be generated when loading coal onto a stockpile, moving coal on a stockpile, or unloading coal from a stockpile. Also, high wind velocities can entrain dust from the surfaces of stockpiles and other exposed areas on surface mines. Once airborne, dust from these sources can expose workers, cause visibility problems, and raise concern with the public if dust exits the mine property. A number of control strategies, including wetting with water, chemical applications, wind fences, and enclosures, have been developed to reduce dust liberation from these sources. Details for these controls are discussed in Chapter 11 of NIOSH RI 9701 [NIOSH 2019].

Coal preparation and mineral processing plants utilize similar equipment to process their respective products, which can result in the generation and release of respirable dust into the air. Some of these common processes include crushing, screening, conveying, and loading. USBM IC 9248 [USBM 1990] and Chapters 5 through 9 in NIOSH RI 9701 [NIOSH 2019] describe technologies that can be used to control respirable dust liberation from these sources.

## References for Chapter 5

79 Fed. Reg. 24814 [2014]. Mine Safety and Health Administration: Lowering miners' exposure to respirable coal mine dust, including continuous personal dust monitors; final rule. To be codified at 30 CFR Parts 70, 71, 72, 75, and 90.

Ainsworth SM, Gero AJ, Parobeck PS, Tomb TF [1995]. Quartz exposure levels in the underground and surface coal mining industry. *Am Ind Hyg Assoc J* 56(10):1002–1007.

ASABE [2013]. Tractors and self-propelled machinery for agriculture—air quality systems for cabs—Part 2: Cab & HVAC design. American Society of Agricultural and Biological Engineers, ANSI/ASABE S613-2.1, St. Joseph, MI.

Bennink C [2007]. Haul roads impact tire life. Date accessed: July 26, 2016.

<http://www.forconstructionpros.com/article/10300067/haul-roads-impact-tire-life>

Bolander P, Yamada A [1999]. Dust palliative selection and application guide. U.S. Department of Agriculture, Forest Service, San Dimas Technology and Development Center, Project Report 9977-1207-SDTDC, 20 p.

Bulger C [2015]. Maintaining frictional resistance on mine road surfaces. Queensland Department of Natural Resources and Mines. Date accessed: July 7, 2016.

<https://www.dnrm.qld.gov.au/?a=299155>

CDC [2000]. Silicosis screening in surface coal miners—Pennsylvania, 1996–1997. Centers for Disease Control and Prevention, *MMWR* 49(27):612–615.

CDC [2012]. Pneumoconiosis and advanced occupational lung disease among surface coal miners—16 states, 2010–2011. Centers for Disease Control and Prevention, *MMWR* 61(23):431–434.

Cecala AB, Organiscak JA, Heitbrink WA, Zimmer JA, Fisher T, Gresh RE, Ashley JD II [2003]. Reducing enclosed cab drill operator's respirable dust exposure at a surface coal operation using a retrofitted filtration and pressurization system. Littleton, CO: Transactions of the Society for Mining, Metallurgy and Exploration, Inc., 314:31–36.

Cecala AB, Organiscak JA, Zimmer JA, Heitbrink WA, Moyer ES, Schmitz M, Ahrenholtz E, Coppock CC, Andrews EH [2005]. Reducing enclosed cab drill operator's respirable dust exposure with effective filtration and pressurization techniques. *J Occup Env Hyg* 2(1):54–63.

Cecala AB, Pollock DE, Zimmer JA [2008]. Reducing dust exposure from contaminated work clothing with a stand-alone cleaning system. In: Wallace, ed. Proceedings of 12<sup>th</sup> U.S./North American Mine Ventilation Symposium, Reno, NV, June 9–11.

Cecala AB, Organiscak JA, Zimmer JA, Hillis MS, Moredock D [2009]. Maximizing air quality inside enclosed cabs with a unidirectional filtration and pressurization system. Littleton, CO: Transactions of the Society for Mining, Metallurgy and Exploration, Inc., 326:71–78.

Cecala AB, Organiscak JA, Noll JD [2012]. Long-term evaluation of cab particulate filtration and pressurization performance. Society for Mining, Metallurgy and Exploration, Inc., Transactions, Littleton, CO, 332:521–531.

Cecala AB, Organiscak JA, Noll JD, Zimmer JA [2016]. Comparison of MERV 16 and HEPA filters for cab filtration of underground mining equipment. *Min Eng* 68(8):50–58

Chekan GJ, Colinet JF [2003]. Retrofit options for better dust control—cab filtration, pressurization systems prove effective in reducing silica dust exposures in older trucks. *Aggr Man* 8(9):9–12.

Countess Environmental [2006]. WRAP fugitive dust handbook. WGA Contract #:30204-111. Western Governors Association, Denver, Colorado.

Cowherd C, Mulesky GE, Kinsey JS [1988]. Control of open fugitive dust sources. Environmental Protection Agency Contract No. 68-02-4395, Midwest Research Institute Project No. 8985-14, Research Triangle Park, North Carolina: U.S. EPA, Office of Air & Radiation, Office of Air Quality Planning and Standards.

EPA [1998]. Section 13.2.2 Unpaved roads. In: *Compilation of Air Pollution Emissions Factors, Vol. I: Stationary Point and Area Sources, 5th Edition AP-42*. Research Triangle Park, North Carolina: U.S. Environmental Protection Agency, Office of Air Quality Planning and Standards, Emission Factor and Inventory Group.

EPA [2020]. What is a HEPA filter? U.S. Environmental Protection Agency. <https://www.epa.gov/indoor-air-quality-iaq/what-hepa-filter-1>

Franta RJ [2016]. Personal communication with NIOSH researchers. November 16, 2016.

Gillies JA, Watson JG, Rogers CF, DuBois D, Chow JC, Langston R, Sweet J [1999]. Long-term efficiencies of dust suppressants to reduce PM<sub>10</sub> emissions from unpaved roads. *J Air Waste Man Assoc* 49:3–16.

Hall NB, Halldin CN, Blackley DJ, Laney AS [2020]. Assessment of pneumoconiosis in surface coal miners after implementation of a national radiographic surveillance program, United States, 2014–2019. *Am J Ind Med* <https://doi.org/10.1002/ajim.23184>

James DE, Piechota TC [2008]. Development of improved water spray patterns from construction water trucks. Presentation at Water Smart Innovations Conference and Exposition, Las Vegas, Nevada.

Listak JM, Reed WR [2007]. Water separator shows potential for reducing respirable dust generated on small-diameter rotary blasthole drills. *Int J Min Rec Env* 21(3):160–172.

Massey BA [2017]. Fresh air intake system for overburden drills. U.S. Patent 9,770, 682 B2. Washington, DC: U.S. Patent and Trademark Office.

Midwest Research Institute [1981]. Dust control for haul roads. U.S. Department of the Interior, Bureau of Mines Open File Report 130-81.

Millgate B, Hagan P [2015]. Changes in drilling performance and dust suppression with the use of a water separator sub. In: Aziz N, Kininmonth B, eds. *Proceedings of the 2015 Coal Operators' Conference, Mining Engineering, University of Wollongong, February 18-20*. <https://ro.uow.edu.au/coal/582>

Moosmüller H, Varma R, Arnot WP, Kuhns HD, Etyemezian V, Gillies JA [2005]. Scattering cross-section emission factors for visibility and radiative transfer applications: military vehicles traveling on unpaved roads. *J Air Waste Man Assoc* 55:1743–1750.

MSHA [2020]. MSHA data sets—16. Quartz samples. U.S. Department of Labor, Mine Safety and Health Administration. <https://arlweb.msha.gov/OpenGovernmentData/OGIMSHA.asp>

NAFA [2020]. Understanding MERV/ NAFA user's guide to ANSI/ASHRAE 52.2. National Air Filtration Association. <https://www.nafahq.org/understanding-merv-nafa-users-guide-to-ansi-ashrae-52-2/>

NIOSH [1992]. Preventing silicosis and deaths in rock drillers. U.S. Department of Health and Human Services, Centers for Disease Control and Prevention, National Institute for Occupational Safety and Health, DHHS (NIOSH) Publication Number 92-107, NIOSH ALERT. <https://www.cdc.gov/niosh/docs/92-107/>

NIOSH [1998]. New shroud design controls silica dust from surface mine and construction blast hole drills. By Page SJ, Organiscak JA, Flesch JP, Hagedorn RT. Pittsburgh PA: U.S. Department of Health and Human Services, Centers for Disease Control and Prevention, National Institute for Occupational Safety and Health, Hazard Control 27.

NIOSH [2001a]. Improved cab air inlet location reduces dust levels and filter loading rates. By Organiscak JA, Page SJ. Pittsburgh PA: U.S. Department of Health and Human Services, Centers for Disease Control and Prevention, National Institute for Occupational Safety and Health, Technology News 485.

NIOSH [2001b]. Floor heaters can increase operator's dust exposure in enclosed cabs. By Cecala AB, Organiscak JA. Pittsburgh PA: U.S. Department of Health and Human Services, Centers for Disease Control and Prevention, National Institute for Occupational Safety and Health, Technology News 486.

NIOSH [2001c]. Sweeping compound application reduces dust from soiled floors within operator cabs. By Organiscak JA, Cecala AB. Pittsburgh PA: U.S. Department of Health and Human Services, Centers for Disease Control and Prevention, National Institute for Occupational Safety and Health, Technology News 487.

NIOSH [2003]. Handbook for dust control in mining. By Kissell FN. Pittsburgh PA: U.S. Department of Health and Human Services, Centers for Disease Control and Prevention, National Institute for Occupational Safety and Health, DHHS (NIOSH) Publication No. 2003-147, Information Circular 9465.

NIOSH [2005]. Improve drill dust collector capture through better shroud and inlet configurations. By Organiscak JA, Page SJ. Pittsburgh PA: U.S. Department of Health and Human Services, Centers for Disease Control and Prevention, National Institute for Occupational Safety and Health, Technology News 512.

NIOSH [2008]. Key design factors of enclosed cab dust filtration systems. By Organiscak JA, Cecala AB. U.S. Department of Health and Human Services, Centers for Disease Control and Prevention, National Institute for Occupational Safety and Health: NIOSH Report of Investigations 9677.

NIOSH [2018]. Design, testing, and modeling of environmental enclosures for controlling worker exposure to airborne contaminants. By Organiscak JA, Cecala AB, and Hall RM. Pittsburgh PA: U.S. Department of Health and Human Services, Centers for Disease Control and Prevention, National Institute for Occupational Safety and Health, DHHS (NIOSH) Publication No. 2018-123, Information Circular 9531.

<https://www.cdc.gov/niosh/mining/works/coversheet2046.html>

NIOSH [2019]. Dust control handbook for industrial minerals mining and processing. Second edition. By: Cecala AB, O'Brien AD, Schall J, Colinet JF, Franta RJ, Schultz MJ, Haas EJ, Robinson JE, Patts J, Holen BM, Stein R, Weber J, Strebel M, Wilson L, Ellis M. Pittsburgh PA: U.S. Department of Health and Human Services, Centers for Disease Control and Prevention, National Institute for Occupational Safety and Health, DHHS (NIOSH) Publication No. 2019-124, Report of Investigations 9701.

<https://www.cdc.gov/niosh/mining/works/cover-sheet2094.html>

Organiscak JA, Reed WR [2004]. Characteristics of fugitive dust generated from unpaved mine haulage roads. *Int J Surf Min Recl Env* 18(4):236–252.

Organiscak JA, Cecala AB, Thimons ED, Heitbrink WA, Schmitz M, Ahrenholtz E [2004]. NIOSH/Industry collaborative efforts show improved mining equipment cab dust protection. *Society for Mining, Metallurgy and Exploration, Inc. Transactions*, Littleton, CO, 314:145–152.

Organiscak JA, Page SJ [2005]. Development of a dust collector inlet hood for enhanced surface mine drill dust capture. *Int J Surf Min Recl Env* 19(1):12–28.

Organiscak JA, Cecala AB, Noll JD [2014]. Using node analysis modeling techniques to predict cab filtration system performance. *Min Eng* 66:52–59.

Page SJ [1991]. Respirable dust control on overburden drills at surface mines. *Coal mining technology, economics, and policy. Proceedings of the American Mining Congress Coal Convention*, Pittsburgh, PA, June 2-5, pp. 523–539.

Page SJ, Organiscak JA [2004]. Semi-empirical model for predicting surface mine drill respirable dust emissions. *Int J Surf Min Recl Env* 18(1):42–59.

Potts JD, Reed WR [2008]. Horizontal air-blocking shelf reduces dust leakage from surface drill shroud. Littleton, CO: *Transactions of the Society for Mining, Metallurgy and Exploration, Inc.*, 324:55–60.

Potts JD, Reed WR [2011]. Field evaluation of air-blocking shelf for dust control on blasthole drills. *Int J Min Rec Env* 25(1):32–40.

Reed WR, Organiscak JA, Page SJ [2004]. New approach controls dust at the collector dump point. *Coal Age* 109(6):20–22.

Reed WR, Organiscak JA [2005]. The evaluation of dust exposure to truck drivers following the lead haul truck. *Trans Soc Min Met Expl Inc.* 318:147–153.

Skorseth K, Selim AA [2000]. Gravel roads: maintenance and design manual. South Dakota Local Transportation Assistance Program, U.S. Department of Transportation, Federal Highway Administration.

Tannant DD, Regensburg B [2001]. Guidelines for mine haul road design. University of British Columbia-Okanagan, School of Engineering. Date accessed: July 7, 2016.

<https://open.library.ubc.ca/cIRcle/collections/facultyresearchandpublications/52383/items/1.0102562>



- Thompson RJ [2020]. Mining roads: mine haul road design, construction & maintenance management. <http://aspasa.co.za/wp-content/uploads/2017/07/road-design-and-maintanance-Molefe.compressed.pdf>
- Thompson RJ, Visser AT [2001]. Mine haul road fugitive dust emission and exposure characterisation. *J Mine Vent Soc of South Africa* 54(1):18–30.
- Thompson RJ, Visser AT [2007]. Selection, performance and economic evaluation of dust palliatives on surface mine haul roads. *J Southern Afr Inst Mining Metallurgy* 107(7):435–450.
- Tomb TF, Peluso RG, Parobeck PS [1986]. Quartz in United States coal mines. In *International Conference on the Health of Miners*, RW Wheeler, ed. Cincinnati, OH: American Conference of Governmental and Industrial Hygienists, pp. 513–519.
- Tomb TF, Gero AJ, Kogut J [1995]. Analysis of quartz exposure data obtained from underground and surface coal mining operations. *Applied Occupational and Environmental Hygiene*, 10(12):1019–1026.
- USBM [1983]. Cost effectiveness of dust control used on unpaved haul roads, Vol. 1 results, analysis, and conclusions. By Rosbury KD, Zimmer RA. U.S. Department of the Interior, Bureau of Mines Open File Report 106-85.
- USBM [1987]. Fugitive dust control for haulage roads and tailings. By Olson KS, Veith DL. U.S. Department of the Interior, Bureau of Mines Report of Investigations 9069.
- USBM [1988]. Impact of drill stem water separation on dust control for surface coal mines. By Page SJ. Pittsburgh, PA: U.S. Department of the Interior, Bureau of Mines, Technology News No. 308.
- USBM [1990]. Dust control in coal preparation and mineral processing plants. By Diver EF, Cecala AB. Pittsburgh, PA: U.S. Department of the Interior, Bureau of Mines, Information Circular 9248.
- Watson JG, Rogers CF, Chow JC, DuBois D, Gillies JA, Derby J, Moosmüller H [1996]. Effectiveness demonstration of fugitive dust control methods for public unpaved roads and unpaved shoulders on unpaved roads. Final Report, DRI Document No. 685-5200.1F1, Prepared for California Regional Particulate Air Quality Study, Sacramento, California: California Air Resources Board.
- Weakley A [2000]. Controlling dust without using bag houses. *Coal Age* 105(11):24–26.
- Zimmer RA, Lueck SR [1986]. Investigation of quartz dust sources and control mechanisms on surface coal mine operations. Volume I—Results, analysis, and conclusions. Golden, CO: PEI Associates, Inc., U.S. Bureau of Mines contract no. JQ348Q32, NTIS: PB 86-215852.
- Zimmer RA, Lueck SR, Page SJ [1987]. Optimization of overburden drill dust control systems on surface coal mines. *Int J Surf Min Rec Env* 1(2):155–157.

## CHAPTER 6: REDUCING FLOAT COAL DUST DEPOSITION

Previous chapters in this handbook have focused on controlling respirable dust generated during the mining and transport of coal in order to reduce the health hazard for miners. Float coal dust is also generated by these same mining processes and poses a serious safety hazard for miners. Float coal dust consists of particles passing a No. 200 sieve [30 CFR 75.400–1<sup>17</sup>]<sup>17</sup>—smaller than 75 micrometers (µm) in size—that are carried by the ventilating air until they deposit onto the roof, ribs, and floor of mine entries. This float coal dust can then be re-entrained into the air, typically by the pressure wave from a methane explosion [NIOSH 2016], which can fuel a more violent coal dust explosion. Once initiated, a coal dust explosion can be self-propagating and widespread throughout a mine in entries where float coal dust has deposited.

In order to mitigate the potential for coal dust explosions, the Mine Safety and Health Administration (MSHA) enforces regulations that are designed to limit the accumulation of float coal dust [30 CFR 75.400] and provide rock dust treatment to inert the float coal dust [30 CFR 75.403]. Sufficient quantities of rock dust (typically limestone) must be applied to raise the total incombustible content of the explosion-entrained mine dust mixture to a minimum of 80%. A challenging aspect of applying rock dust is that it must be repeatedly or continuously applied during production shifts to prevent the development of an explosive coal dust layer on top of an underlying layer of rock dust. NIOSH research has shown that only the top 3/32 to 5/32 inches of the floor dust layer is stripped off or entrained into the air during a typical float coal dust explosion [NIOSH 2006]. This same research showed that a 1/200-inch-thick layer of pulverized coal dust deposited on top of a 3/8-inch-thick uniform concentration of 80% rock dust and 20% float coal dust would propagate an explosion. Figure 6.1 illustrates a similarly explosive thin layer of float coal dust deposited on a layer of rock dust.

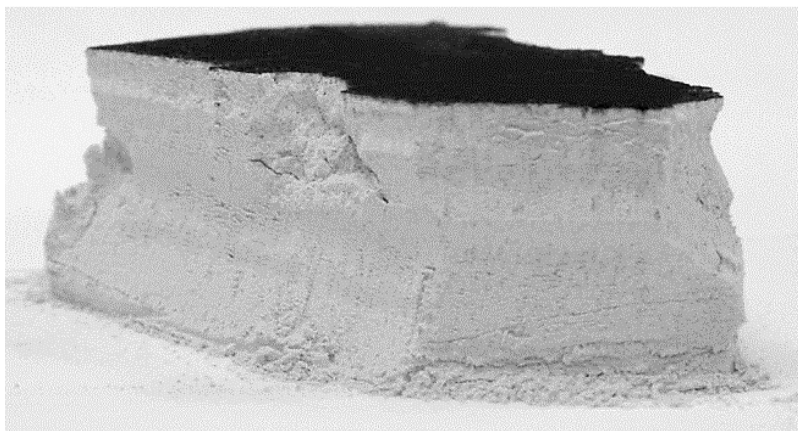

Photo by NIOSH

**Figure 6.1. Cross-section of a 1/100-inch-thick explosible float coal dust layer deposited on top of a 3/4-inch-thick layer of rock dust.**

MSHA routinely inspects mine entries for compliance with the float coal dust regulations and historically, has found many violations. From 2008 through 2014, over 49,000 violations of 30 CFR 75.400 and nearly 11,000 violations of 30 CFR 75.403 were reported [NIOSH 2016].

---

<sup>17</sup> Code of Federal Regulations. See CFR in references.

More recent data on MSHA's website shows that total violations from 2015 through 2020 were 21,500 for 30 CFR 75.400 and over 7,200 for 30 CFR 75.403 [MSHA 2021]. It is apparent that coal mines have had and continue to experience difficulty with controlling and inerting float coal dust depositions. Therefore, NIOSH initiated research to identify control technologies that could be implemented by mines to reduce float coal dust levels. As part of this research effort, NIOSH also investigated methods that could be used to sample float coal dust. Results of this research are discussed below.

## Float Dust Sampling

Past research efforts to quantify float dust deposition in mine entries involved placing deposition pans in the mine entry and allowing the float dust to naturally settle onto plastic sheets [Kost et al. 1981] or "shark skin" filter paper sheets [Bhaskar et al. 1988]. These deposition sheets were then collected and transported to a laboratory for post-weighing to determine the mass of float dust that had settled onto the sheet. Although effective, this sampling technique was time consuming in order to collect sufficient dust mass on the sheets. Also, the sheets were subject to contamination during sampling from material falling from the mine roof. Dust loss or contamination could also occur during the collection and handling of the sheets.

### Institute of Occupational Medicine (IOM) Sampler

For NIOSH's research purposes, a sampling method was desired that would enable the airborne sampling of float-dust-sized particles so that evaluation of control technologies could be conducted in the dust galleries at the Pittsburgh laboratory over shorter time frames. As mentioned previously, float dust is less than 75  $\mu\text{m}$  in size; therefore, samplers that would collect dust encompassing this size range were sought, but none were available to collect this specific size range of particles. A sampler specifically designed to collect the inhalable fraction of airborne dust, which is less than 100  $\mu\text{m}$  as defined by the American Conference of Governmental Industrial Hygienists (ACGIH), was shown to collect a representative sample of particles less than 75  $\mu\text{m}$  [Mark and Vincent 1986]. This Institute of Occupational Medicine (IOM) inhalable sampler has a 15-millimeter (mm) diameter open inlet leading to a 25-mm diameter filter as shown in Figure 6.2, left. The sampler is operated at a flow rate of 2 liters per minute (L/min) and is fabricated in plastic or stainless steel versions. The stainless steel versions have stable mass in different humidity environments [Smith et al. 1998] and were selected by NIOSH for sampling of airborne float dust. The entire sampling cassette is designed to be weighed so that any dust particles that deposit on the walls of the sampler will be included in the measured mass. Past research has shown the IOM sampler provides a representative sample of the defined inhalable particles size distribution [Woehkenberg and Bartley 1998] and is viewed to be a reference sampler for the inhalable fraction [Koch et al. 2002].

Although the standard IOM sampler is an open-face design, NIOSH designed and fabricated an inlet adapter, as a replacement for the front plate, that would allow for isokinetic sampling as shown in Figure 6.2, right [Patts and Barone 2017]. Isokinetic sampling matches the sampler inlet velocity to the velocity of the airstream being sampled, thus minimizing errors resulting from particle inertia in uneven airstreams [Wilcox 1956]. When used for sampling in the laboratory or in mines, air velocity measurements in feet per minute (fpm) were obtained in the entry by NIOSH and the appropriate isokinetic nozzles were used with the IOM samplers.

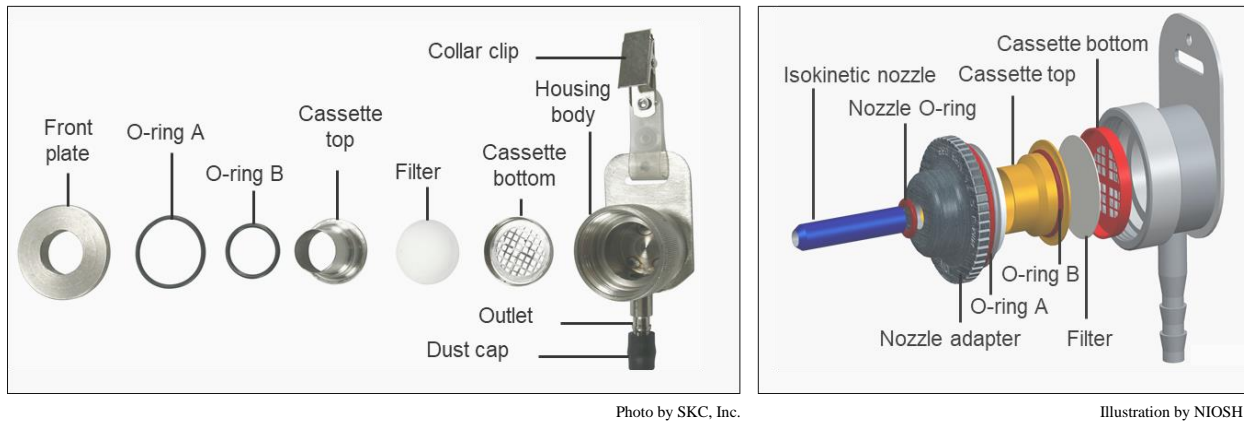

**Figure 6.2. Photo (left) illustrating components of standard stainless steel IOM sampler. Illustration (right) showing the nozzle adapter and isokinetic nozzle designed by NIOSH.**

### *Low-temperature Ashing (LTA)*

As discussed later in this chapter, NIOSH evaluated a flooded bed scrubber that was used with an auxiliary face fan to remove float dust before the ventilating air was discharged into the return entry. Sampling in the heavily rock-dusted return entry allowed limestone rock dust to be entrained in the high-speed air discharged from the auxiliary fan. In order to isolate the impact of the scrubber for reducing float coal dust, a low-temperature ashing (LTA) analytical method was developed by NIOSH to quantify the coal fraction in mixed dust samples collected with stainless steel IOM samplers [Barone et al. 2016]. With this method, the IOM samplers containing the mixed dust samples were heated at 105°C for 2 hours to remove moisture and then weighed to determine dry mass. The samples were then heated at 515°C for 2.5 hours in a muffle furnace to remove the combustible content, which represents the coal portion of the sample. The samples were reweighed to quantify the float coal dust in the samples. Testing using this method with known mixtures of coal and rock dust resulted in measurements that differed in mass by 0.5% or less from the known quantities, validating the method for analyzing mixed dust samples obtained in the mine. This LTA method is similar to the procedures used by the National Air and Dust Laboratory of MSHA to determine incombustible content of float dust samples collected by inspectors [NIOSH 2010].

### *Float Dust Personal Dust Monitor*

In addition to the IOM sampler, NIOSH has also utilized a modified Thermo Scientific PDM3600 Personal Dust Monitor (PDM) for measuring airborne float dust. The Model 3600 and Model 3700 PDMs are near real-time respirable dust samplers approved for use in underground coal mines. The Model 3700 version of the PDM was described in detail in Chapter 2, with current MSHA regulations requiring underground coal mine operators to use this model for respirable dust compliance sampling. The Model 3600 was the original design of the PDM and incorporated a cap lamp with the dust sampler. NIOSH modified the PDM3600 sampler by removing the tapered-element oscillating microbalance (TEOM) module from the body of the sampler and placing it into a NIOSH-fabricated external sampling housing as shown in Figure 6.3, left. Total airborne dust can be collected through an isokinetic nozzle mounted in the top of the external module as shown in Figure 6.3, center. To maintain communication with, supply power to, and pull dust-laden air into the externally operated TEOM module, a second



module was fabricated with the appropriate air and electrical connections as shown in Figure 6.3, center. This second module is inserted into the TEOM port in the PDM body. Float dust samples can be collected with the modified PDM as shown in Figure 6.3, right.



Photos by NIOSH

**Figure 6.3. External sampling housing with the TEOM unit inserted (left). The external TEOM module with isokinetic nozzle is connected to airflow and electrical module (center), which inserts into the PDM body. A modified TEOM module is mounted on a sampling basket (right).**

The advantage of using this modified PDM sampler for airborne float dust sampling is that it records dust mass measurements every minute into a downloadable file. This file can then be used to identify elevated dust periods and to calculate dust concentrations for desired time frames, such as with dust controls on and controls off. NIOSH originally utilized this instrument in laboratory testing and then wanted to use it for underground coal mine sampling. However, because the original PDM3600 design was modified, the intrinsic safety approval for use in underground coal mines was invalidated. As a solution, NIOSH was able to obtain an experimental-use permit from MSHA in order to use this sampler in underground coal mines.

NIOSH conducted five tests in an environmentally controlled dust chamber to compare float dust concentrations measured with two IOM samplers to concentrations measured with two float dust PDMs (unpublished data). The average float dust concentration measured with the IOM samplers was 14.7 milligrams per cubic meter of air ( $\text{mg}/\text{m}^3$ ) and 14.3  $\text{mg}/\text{m}^3$  with the float dust PDMs. The PDMs measured 2.7% less float dust on average than the IOM samplers. This difference was not statistically significant at a 95% confidence level, indicating that the modified PDM provides comparable measurements of airborne float dust.

## Float Dust Control Technologies

NIOSH conducted sampling in the return on a continuous miner section, on a longwall face, and in a belt entry with two transfer points to quantify float and respirable dust levels [Shahan et al. 2017]. The continuous mining section was using exhausting face ventilation developed with tubing and an auxiliary fan located in the return. The longwall was approximately 700 ft long and using bidirectional cutting. The area of the belt entry sampled contained two transfer points approximately 3,800 feet apart. At Transfer A, the belt-to-belt transfer was at a 30-degree angle, while the belt-to-belt transfer at B was a 90-degree transfer.



Additional detail for each of these operations and the specific sampling methodologies can be found in the cited reference.

Airborne float and respirable dust levels from these surveys, measured in  $\text{mg}/\text{m}^3$ , are summarized in Table 6.1. At each of these operations, elevated levels of float dust were generated, particularly on the continuous and longwall sections. As expected, significantly lower levels of respirable dust were measured. These float dust levels indicate that implementation of control technologies would be beneficial at these mining operations.

Similar to the approach discussed for controlling respirable dust, the approach for minimizing float coal dust deposition should begin with achieving efficient cutting to minimize overall dust generation. Then supplemental engineering controls can be implemented to reduce airborne dust levels. Discussion of several supplementary control technologies that have been evaluated for float dust control by NIOSH follows.

**Table 6.1. Summary of float and respirable dust levels for three different mining operations [Shahan et al. 2017]**

<b>Mining operation</b>	<b>Average air velocity, fpm</b>	<b>Sampling location</b>	<b>Float dust, <math>\text{mg}/\text{m}^3</math></b>	<b>Respirable dust, <math>\text{mg}/\text{m}^3</math></b>
Continuous miner	551	200 ft downwind of auxiliary fan	90.1	6.5
		300 ft downwind of auxiliary fan	76.1	6.4
		400 ft downwind of auxiliary fan	68.6	6.7
Longwall	1,158	Intake—last open crosscut	0.50	0.02
		Belt—outby stageloader	1.44	0.25
		180 ft from headgate	14.76	0.80
		380 ft from headgate	56.60	2.63
		690 ft from headgate	52.60	2.65
Belt entry and transfers	89	40 ft upwind of transfer A	0.97	0.09
		10 ft downwind of transfer A	13.27	0.61
		50 ft downwind of transfer A	3.20	0.34
		75 ft downwind of transfer A	3.03	0.31
		3,765 ft downwind of A; 40 ft upwind of B	2.69	0.36
		10 ft downwind of transfer B	11.85	0.94

## Return Entry Flooded Bed Scrubber

Underground coal mines can use auxiliary fans with ventilation tubing to provide exhausting or blowing ventilating air to the mining faces. For exhaust ventilation, an auxiliary fan is located in the return entry and pulls dust-laden air from the face through the tubing. This air is discharged down the return entry, where float coal dust can deposit. It is then necessary to apply sufficient quantities of rock dust to inert the deposited float coal dust.

NIOSH conducted a case study with a mining company to evaluate the use of a flooded bed scrubber installed inline between the ventilation tubing and the auxiliary fan to filter dust out of the ventilating air before it is discharged into the return entry [Patts et al. 2016]. The flooded bed scrubber was approximately 10 ft long by 4.3 ft wide by 5.2 ft high and was mounted on skids as shown in Figure 6.4, left. The stainless steel filter panel was 4.3 ft wide by 3.6 ft high and was wetted by 12 spray nozzles as shown in Figure 6.4, right. A mist eliminator was positioned outby the filter panel to remove dust-laden water from the airstream, which was pumped to a standalone 1.6-cubic-yard recirculation water tank. The water tank contained three cascading settling chambers and was also mounted on skids. Airflow pulled through the scrubber by the auxiliary fan averaged approximately 17,000 cubic feet per minute (cfm) over the three shifts of testing by NIOSH.

A rock duster was positioned at the fan discharge and was operated continuously by the mine. NIOSH planned to place dust sampling stations 200, 300, and 400 ft outby the auxiliary fan in the return. These samplers would be inundated with rock dust under these normal operating conditions. However, the mine received approval from MSHA to place a continuously operating trickle duster just outby the last NIOSH sampling station to dust the majority of the return entry. While NIOSH was sampling when a cut was being taken at the face, the rock duster at the auxiliary fan did not have to be operated. In between cuts and sampling, the rock duster at the fan was operated to apply rock dust to the 400-foot portion of the entry not covered by the trickle duster.



Photos by NIOSH

**Figure 6.4. Flooded bed scrubber unit (left) and 12 water sprays used to wet filter panel (right).**

At each of the three sampling stations, NIOSH collected airborne float dust samples with the IOM sampler, airborne respirable dust samples with 10-mm nylon cyclones, and deposition samples in steel tins. Because of the heavy rock deposition already in the return entry and high discharge velocity of the auxiliary fan, rock dust was entrained into the return air even though the rock duster at the auxiliary fan was not being operated during NIOSH sampling periods. As a

result, the low temperature ashing analytical method mentioned in the previous section was used to quantify the coal dust fraction of the samples collected with the IOM sampler. Average reductions over the three sampling stations was 92.5% for airborne float coal dust, 85.5% for respirable dust, and 84.2% for the deposition samples.

It was apparent that the flooded bed scrubber was effectively removing all sizes of dust particles from the return airstream. To visually illustrate the effectiveness of the scrubber, Figure 6.5, left, shows the return entry after a cut when the scrubber was not being operated, while Figure 6.5, right, shows the same return entry after a cut with the scrubber operating. The left photo shows the dark float coal dust deposited in the entry, while the right photo shows the white rock dust without significant coal dust deposition. Both photos were taken immediately after the cuts were completed and before the application of additional rock dust.



Photos by NIOSH

**Figure 6.5. Return entry after a cut without (left) and with flooded bed scrubber operating (right) illustrating difference in float coal dust deposition.**

## Water Sprays

NIOSH has completed research to quantify the ability of water sprays to capture airborne float coal dust [Beck et al. 2018]. Testing was conducted in a modified section of the NIOSH full-scale longwall dust gallery in Pittsburgh. Line brattice was suspended from the gallery roof to construct an isolated test area that was 62.5 ft long by 5.4 ft high by 3.0 ft wide. Air velocity through the test area was 700 fpm. Feed material for these tests was produced with coal from the Pocahontas 3 seam, with all coal passing through a 200-mesh screen ( $< 75 \mu\text{m}$ ) and having a mean diameter of  $23 \mu\text{m}$ . Dust was dispersed near the test area entrance with a compressed-air-powered venturi educator. A water spray was mounted 24 ft downwind at the roof, and dust sampling was conducted at the exit of the test area (58.5 ft downwind from the dust release point). Dust sampling was conducted with three IOM samplers fitted with isokinetic nozzles. A programmable mobile sampling stand moved the three IOM samplers through an X-Y plane sampling grid containing 15 points (three across and five down). At each sampling point in the grid, dust would be collected for one minute before moving to the next grid point. Utilization of the sampling grid minimized the impact on measurement accuracy resulting from dust gradients that may have been present.

Seven different water sprays were evaluated for their float dust capture ability. These sprays (spray type-spray angle in degrees) included the following:

- a full cone (FC) spray (FC-59)
- two hollow cone (HC) sprays (HC-33) and (HC-81)
- two flat fan (FF) sprays (FF-25) and (FF-50)
- a hydraulic atomizing (HA) spray (HA-88)
- an air atomizing (AA) spray (AA-21)

The FC, HC, FF, and HA sprays were tested at 80 pounds per square inch (psi) (low psi) and 160 psi (high psi). The AA spray was tested with air and water pressure both set to 25 psi (low psi) and then both at 50 psi (high psi). Sprays were angled 45 degrees down from the roof and oriented with the spray directed either into or with the ventilating airflow. Three replicates were completed for each test condition leading to a total of 84 tests.

The FC spray when operated at 160 psi and oriented into the airstream had the highest airborne float coal dust reduction at 40.1%, as shown in Figure 6.6. All sprays except for the AA nozzle when oriented into the air had greater dust collection efficiency when operated at the higher test pressure. This trend matches that found previously for the collection of airborne respirable dust from multiple research efforts [Tomb et al. 1972; USBM 1982; Pollock and Organiscak 2007]. Also, for the HC and FF sprays that were tested with two different spray angles, the wider spray angle resulted in higher dust reductions for all test conditions. Spray orientation had mixed results, with some spray type/pressure combinations showing dust reductions but not others.

Airborne float coal dust reduction, %

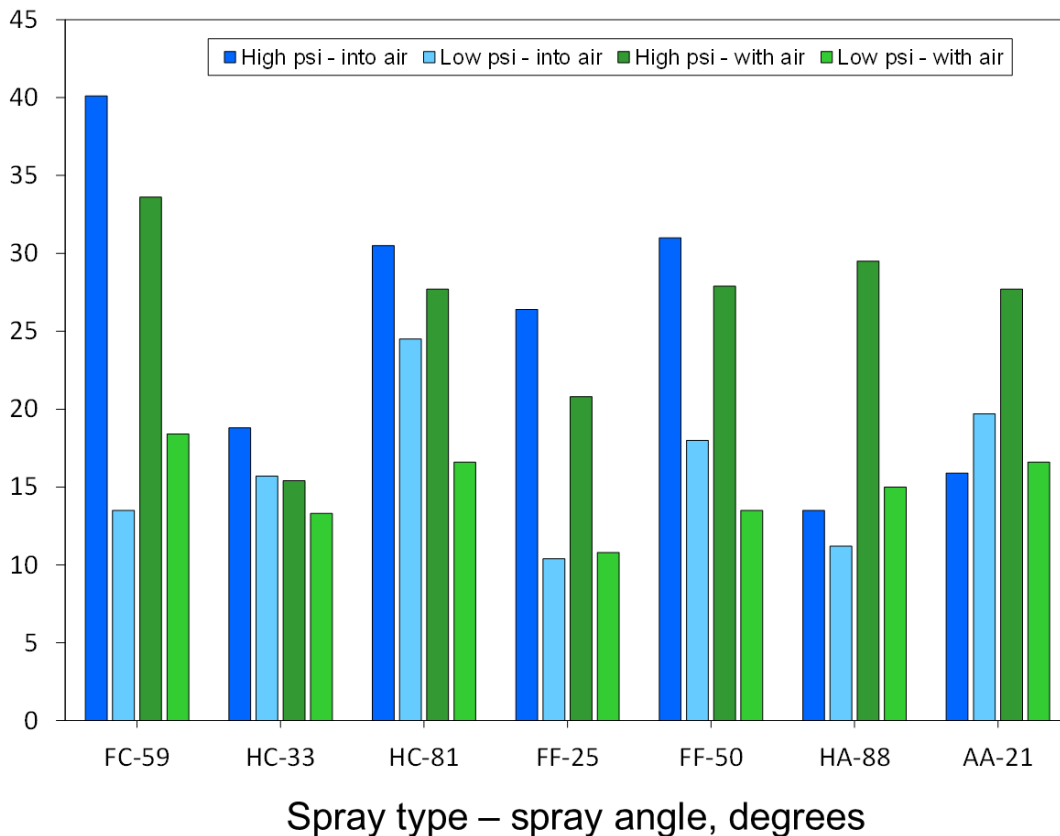

Figure 6.6. Impact of spray type, operating pressure, and orientation on reducing airborne float coal dust.

It should be noted that the sprays traditionally used in underground coal mines (FC, HC, and FF) used between 0.96 and 1.20 gallons per minute (gpm) when operated at 160 psi and between 0.75 and 0.86 gpm when operated at 80 psi [Beck et al. 2018]. In contrast, the HA nozzle only used 0.45 gpm at 160 psi and 0.33 gpm at 80 psi, which is approximately 45% of the water used by the FC spray. Because of the much lower water flow rate used by the HA nozzle, it had the highest dust reduction on a relative per gallon basis when the sprays were operated at 80 psi. This may make it a more desirable selection if water pressure and flow rate are concerns.

### Water Curtain on Longwall

The position of the shearer on the longwall face and the face air velocity will impact the quantity of generated float dust that gets carried to the return entry for any individual longwall. However, the data in Table 6.1 shows that an average of over 50 mg/m<sup>3</sup> of float dust was present just upwind of the return entry. In an effort to reduce the amount of float coal dust entering and depositing in the return, NIOSH investigated the potential dust reduction obtained with a water curtain designed for use on a longwall face [Seaman and Beck 2020]. Testing was conducted in the NIOSH full-scale longwall dust gallery to evaluate single and dual water curtains with different spray nozzle spacing to quantify reductions in float dust levels. Each water curtain contained three spray manifolds approximately three feet in length. The manifolds were mounted to the roof with the sprays oriented downward for testing as shown in Figure 6.7.



Photo by NIOSH

**Figure 6.7. Laboratory testing of a water curtain for reducing float dust on a longwall face.**

Coal dust used for these tests was custom-milled to contain float-dust-sized particles and had a mean particle size of 23 μm as mentioned previously. Dust feed was adjusted to produce a dust cloud of approximately 50 mg/m<sup>3</sup>. Airborne float dust samples were collected with the modified PDM3600 as described earlier in this chapter. Respirable dust samples were collected with a PDM3700 sampler. Two float dust PDMs and one PDM3700 were mounted on a programmable



mobile sampling stand that moved the samplers through an X-Y sampling plane, with each test taking 25 minutes to move through the sampling grid points.

The initial spray bar tested was equipped with 21 full cone sprays spaced six inches apart and operated at 160 psi. These sprays are rated at 1.08 gpm at this operating pressure. Subsequent tests removed sprays which increased the distance between nozzles until only three sprays were operated. The greatest dust reductions were observed with all 21 sprays operating, resulting in a 49% float dust reduction and a 33% reduction in respirable dust. As sprays were removed, the float dust and respirable dust reductions consistently dropped to minimums of less than 20% and 5%, respectively, with three sprays operating. When examining dust reduction per gallon of water used, a nozzle spacing of 12 inches returned the highest per-unit reduction.

Tests were then conducted with two water curtains operating simultaneously. For tests with the spray curtains separated by 6.5 ft and 21 sprays operating in each, float and respirable dust were reduced by 56% and 43%, respectively. Although this dual-bar testing resulted in overall increased dust reductions, the dust reduction per gpm was lower because of using twice as much water. Tests were then conducted to compare the same number of sprays on a single water curtain to an equivalent number of sprays spread over two water curtains—for example, 12 sprays on one bar versus 6 sprays on each of two manifolds with the spacing of the sprays such that they were offset from one bar to the other. These tests showed slight improvements when using two water curtains, but the differences were not significant.

For tests conducted with the spray curtains separated by 42.5 ft and 21 sprays operating in each, float and respirable dust were reduced by 44% and 27%, respectively. These reductions were less than those found for the single spray curtain, so no benefit was realized by separating the water curtains. The verification code for this document is 445201

This testing illustrates the potential for reducing the quantity of float dust that would enter the return entry with the use of a water curtain on a longwall face. Implementation and testing on an operating longwall are needed to quantify in-mine performance.

### Conveyor Belt Transfer Controls

Transferring coal from one conveyor belt to another releases float and respirable dust into the ambient air and can be a problematic dust source. The application of water and water with an added wetting agent were evaluated by NIOSH at an underground transfer point to determine the potential dust reduction with these controls [Beck et al. 2020]. At the mine test site, coal was transferred from a 48-inch wide discharge belt onto a 48-inch-wide receiving belt, which was oriented 90 degrees to the discharge belt. The coal would drop approximately five feet from the first to second belt. The belt transfer was partially enclosed and had vertical rubber belting installed across the opening of the receiving belt to minimize airflow through the transfer chute. Airflow in the belt entry moved in the opposite direction of belt travel and was less than 100 fpm at the belt transfer location. Average coal flow through the transfer point during testing was 870 tons per hour but fluctuated between 560 to 1,135 tons per hour.

Four water sprays were installed at the belt transfer. Two sprays were mounted above the coal stream at the discharge belt as shown in Figure 6.8, with two other sprays mounted on the underside of the coal stream. All of these sprays had a flat fan spray pattern with a 40-degree spray angle. The sprays were oriented so the spray patterns would cover the full width of the coal stream. The sprays were operated at 35–40 psi, which resulted in a flow rate of 8 gpm and added

moisture to the coal product of 0.24%–0.29% by weight. A material flow sensor monitored the receiving belt to provide input to a controller that would open a solenoid valve in the water supply line to automatically activate the sprays when coal movement was detected on the belt.



Photo by NIOSH

**Figure 6.8. Water sprays directed at top of coal stream being discharged from belt.**

A chemical injection pump was used to supply wetting agent to the water at a concentration of 0.2% for the wetting agent portions of the testing. At the water spray flow rate of 8 gpm, wetting agent usage was approximately one gallon per hour. The goal of adding a wetting agent is to lower the surface tension of the water to aid in improving the capture of coal dust. During these tests, the surface tension of the mine water was measured and found to be 59.5 dynes per centimeter (dynes/cm). With the wetting agent added, the surface tension was lowered to 29.3 dynes/cm.

A baseline test period of two hours was conducted with no water sprays operating and was then followed by a two-hour test period of water only or water with wetting agent added. Five test periods each for water and water with wetting agent were completed. Four dust sampling stations were located around the belt transfer point. At each sampling station, a modified PDM3600 was operated to collect an airborne float dust sample along with a PDM3700 to collect an airborne respirable dust sample. The data from these four sampling locations were used to calculate an average dust concentration for each sampling period. The average dust level for either a water only or water with wetting agent test period was compared to the baseline sampling period immediately preceding it to calculate the dust reduction for that test sequence. The average airborne float dust reduction was 32.3% with water only and 49.5% with wetting agent added. The average respirable dust reduction was 28.3% with water only and 46.4% with wetting agent added. The addition of this control system at the transfer point was effective in reducing both float and respirable dust levels.

## References for Chapter 6

- Barone TL, Patts JR, Janisko SJ, Colinet JF, Patts LD, Beck TW, Mischler SE [2016]. Sampling and analysis method for measuring airborne coal dust mass in mixtures with limestone (rock) dust. *J Occ Env Hyg* 13(4):288–296.
- Beck TW, Seaman CE, Shahan MR, Mischler SE [2018]. Open-air sprays for capturing and controlling airborne float coal dust on longwall faces. *Min Eng* 70(1):42–48.
- Beck TW, Seaman CE, Klima SS [2020]. Dust control at a belt conveyor transfer point using water sprays and a wetting agent. Society of Mining, Metallurgy, and Exploration Annual Meeting, Phoenix, AZ, February 23–26, Preprint 20-110.
- Bhaskar R, Ramani RV, Jankowski RA [1988]. Experimental studies on dust deposition in mine airways. *Min Eng* 40(3):191–195.
- CFR. Code of Federal regulations. Washington, DC: U.S. Government Printing Office, Office of the Federal Register.
- Koch W, Dunkhorst W, Lodding H, Thomassen Y, Skaugset NP, Nikanov A, Vincent J [2002]. Evaluation of the Respicon® as a personal inhalable sampler in industrial environments. *J Env Mon* 4(5):657–662.
- Kost JA, Colinet JF, Shirey GA [1981]. Field survey of float dust in coal mining operations. Monroeville, PA: Bituminous Coal Research, Inc., U.S. Bureau of Mines contract no. J0308030, NTIS Publication No. PB82-172719/XAB.
- Mark D, Vincent JH [1986]. A new personal sampler for airborne total dust in workplaces. *Ann Occ Hyg* 30(1):89–102.
- MSHA [2021]. Top 20 most frequently cited standards by mine type. U.S. Department of Labor, Mine Safety and Health Administration. <https://www.msha.gov/top-20-most-frequently-cited-standards-mine-type>
- NIOSH [2006]. Float coal dust explosion hazards. Pittsburgh, PA: U.S. Department of Health and Human Services, Centers for Disease Control and Prevention, National Institute for Occupational Safety and Health. DHHS (NIOSH) Publication No. 2006-125, Tech News 515.
- NIOSH [2010]. Recommendations for a new rock dusting standard to prevent coal dust explosions in intake airways. By Cashdollar KL, Sapko MJ, Weiss ES, Harris ML, Man CK, Harteis SP, Green GM. Pittsburgh, PA: U.S. Department of Health and Human Services, Centers for Disease Control and Prevention, National Institute for Occupational Safety and Health. DHHS (NIOSH) Publication No. 2010-151, Report of Investigations 9679.
- NIOSH [2016]. Review of rock dusting practices in underground coal mines. By Harteis SP, Alexander DW, Harris ML, Sapko MJ, and Weiss ES. Pittsburgh, PA: U.S. Department of Health and Human Services, Centers for Disease Control and Prevention, National Institute for Occupational Safety and Health. DHHS (NIOSH) Publication No. 2017-101, Information Circular 9530.
- Patts JR, Colinet JF, Janisko SJ, Barone TL, Patts LD [2016]. Reducing float coal dust: Field evaluation of an inline auxiliary fan scrubber. *Min Eng* 68(12):63–68.

Patts JR, Barone TL [2017]. Comparison of coarse coal dust sampling techniques in a laboratory-simulated longwall section. *J Occ Env Hyg* 14(5):323–334.

Pollock D, Organiscak J [2007]. Airborne dust capture and induced airflow of various spray nozzle designs. *Aer Sci Tech* 41(7):711–720.

Seaman CE, Beck TW [2020]. Laboratory testing of a water curtain designed to reduce float dust accumulations in longwall returns. Society of Mining, Metallurgy, and Exploration Annual Meeting, Phoenix, AZ, February 23–26, Preprint 20-032.

Shahan MR, Seaman CE, Beck TW, Colinet JF, Mischler SE [2017]. Characterization of airborne float coal dust emitted during continuous mining, longwall mining and belt transport. *Min Eng* 69(9):61–66.

Smith JP, Bartley DL, Kennedy ER [1998]. Laboratory investigation of the mass stability of sampling cassettes from inhalable aerosol samplers. *Am Ind Hyg Assoc J* 59(8):582–585.

Tomb TF, Emmerling JE, Kellner RH [1972]. Collection of airborne coal dust by water spray in a horizontal duct. *Am Ind Hyg Assoc J* 33(11):715–721.

USBM [1982]. Dust knockdown performance of water spray nozzles. Pittsburgh, PA, U.S. Department of the Interior, Bureau of Mines, Technology News No. 150.

Wilcox JD [1956]. Isokinetic flow and sampling. *J Air Pol Con Assoc* 5(4):226, 245.

Woehkenberg ML, Bartley DL [1998]. Inhalable aerosol samplers. *Appl Occup Env Hyg* 13(5):274–278.





Promoting productive workplaces through safety and health research

DHHS (NIOSH) Publication No. 2021-119

DOI: <https://doi.org/10.26616/NIOSH PUB2021119>