



Healthcare Facilities and Power Outages

*Guidance for State, Local, Tribal, Territorial, and
Private Sector Partners*

August 2019



FEMA



ASPR
ASSISTANT SECRETARY FOR
PREPAREDNESS AND RESPONSE

This page intentionally left blank.

Table of Contents

INTRODUCTION.....	1
Purpose	1
Background	1
HEALTHCARE FACILITY PREPAREDNESS.....	3
Challenges to Healthcare Resilience During Power Outages	3
Good Practices to Overcome Challenges	5
Overview of Emergency Preparedness Regulations, Codes, and Standards	8
Considerations Regarding Regulations.....	10
INTEGRATING EMERGENCY PREPAREDNESS EFFORTS	13
Integrated Community-Based Planning	13
Additional Opportunities for Collaboration.....	15
PRIORITIZING ASSISTANCE TO HEALTHCARE FACILITIES DURING RESPONSE	17
Roles and Responsibilities in Assistance Prioritization	17
Using the Community Lifelines to Prioritize Assistance	19
Conclusion	20
APPENDIX A. BASICS OF UTILITY AND STANDBY POWER IN HEALTHCARE.....	21
Overview of Utility Power Transmission and Distribution Systems	21
Overview of Temporary Power.....	22
APPENDIX B. EXCERPTS FROM THE POWER OUTAGE INCIDENT ANNEX.....	26
Federal Government Initial Objectives	26
Federal Operational Phases	26
Facts, Planning Assumptions, and Critical Considerations to Aid in Planning for Prioritizing Assistance.....	29
Critical Information Requirements and Essential Elements of Information for Prioritizing Assistance.....	31
APPENDIX C. RESOURCES	33
Healthcare Emergency Preparedness Regulations and Standards.....	33
Guidance.....	34
Information.....	35
Training	36
Modeling Tools	38
APPENDIX D. ACRONYM LIST.....	40

This page intentionally left blank.

Introduction

Purpose

This document provides guidance and resources on improving healthcare facility resilience to power outages. Resilience is the backbone of emergency management. The Nation's ability to weather storms and disasters without experiencing loss significantly reduces our risk. The Federal Emergency Management Agency (FEMA) developed this guide in collaboration with, and support from, the U.S. Department of Health and Human Services' (HHS) Office of the Assistant Secretary for Preparedness and Response (ASPR) and other partners to meet, in part, the requirements of Section 1208 of the Disaster Recovery Reform Act.¹ This document informs state, local, tribal, and territorial governments, first responders, utility companies, and healthcare facilities on:

- Healthcare facility preparedness standards and challenges;
- Ways to integrate emergency preparedness efforts throughout the whole community; and
- Methods for prioritizing assistance to hospitals, nursing homes, and other long-term care facilities during power outages.

Background

Across the Nation, in every community, there are individuals in hospitals, nursing homes, and other long-term care facilities dependent on power for their well-being. A wide range of facilities provide care in the United States. A portion of these facilities fall within the seventeen provider and supplier types² regulated by states and the Centers for Medicare and Medicaid Services (CMS), including emergency preparedness regulations.³ A portion (e.g., assisted living facilities, board and care homes, individuals living at home) are not regulated by CMS but still may have electrically-dependent residents.

Individuals rely on electricity in a number of ways. Patients of some facilities, such as hospitals, receive acute medical care that relies on electricity. Other individuals with access and functional needs⁴ or chronic health conditions rely on power-dependent durable medical equipment (e.g.,

¹ The Disaster Recovery Reform Act is part of H.R. 302 – FAA Reauthorization Act of 2018.

<https://www.congress.gov/bill/115th-congress/house-bill/302/>.

² The 17 provider and supplier types identified by CMS are: Religious Nonmedical Health Care Institutions, Ambulatory Surgical Centers, Hospices, Psychiatric Residential Treatment Facilities, Programs for All-Inclusive Care for the Elderly, Hospitals, Transplant Centers, Long-term Care Facilities, Intermediate Care Facilities for Individuals with Intellectual Disabilities, Home Health Agencies, Comprehensive Outpatient Rehabilitation Facilities, Critical Access Hospitals, Providers of Outpatient Physical Therapy and Speech-Language Pathology Services, Community Mental Health Centers, Organ Procurement Organizations, Rural Health Clinics and Federally Qualified Health Centers, and End-Stage Renal Disease Facilities.

³ 81 Federal Register (FR) 63859: [Medicare and Medicaid Programs: Emergency Preparedness Requirements for Medicare and Medicaid Participating Providers and Suppliers](#).

⁴ Access and Functional Needs: Individuals having access and functional needs may include, but are not limited to, people with disabilities, older adults, and individuals with limited English proficiency, limited access to transportation, and/or limited access to financial resources to prepare for, respond to, and recover from the emergency.

powered wheelchairs, ventilators), but may reside in an assisted living facility, board and care home, or their own home. Individuals also may have an implanted cardiac device that must be plugged in to recharge. Some individuals cannot regulate their own body temperatures and are vulnerable to a lack of environmental controls such as air conditioning.

Healthcare facility buildings also rely on electricity for many operations, including lighting, security systems, fire alarm and egress systems, environmental controls (e.g., air conditioning), electronic health records, and an array of electricity-dependent durable medical equipment and devices to provide care. In addition, resident populations require daily support (food, water, and transportation) all of which require an intact electrical supply. These requirements, and the fact that healthcare facilities generally cannot temporarily suspend operations, make healthcare facilities uniquely susceptible to power outages. Without power, facilities may require evacuation, and evacuation carries significant dangers for specific populations such as those with access and functional needs.

All levels of government and the private sector have long recognized the importance of power at healthcare facilities, and yet challenges occur with almost every major disaster. One of the more frequent response stabilization activities is providing temporary power (e.g., generator) support for hospitals and skilled nursing facilities. This phenomenon recurs for a multitude of reasons, and although healthcare facility leaders are responsible for preparing their facilities for power outages in accordance with applicable regulation, the whole community (to include all levels of government and utility operators) can help improve these facilities' resilience to power outages.

Healthcare Facility Preparedness

Resilience to power outages begins with the facility and its leadership. Facilities that prepare and plan for the unexpected will be less likely to have catastrophic failures and will be able to request and receive temporary assets faster, if needed.

This section discusses challenges to maintaining healthcare operations during a power outage, good practices to increasing facility resilience, regulations requiring healthcare emergency preparedness, and areas of consideration with regards to regulations.

Challenges to Healthcare Resilience During Power Outages

Generating standby power during a power outage is a complex undertaking. Numerous challenges can impact the ability of a facility to provide adequate emergency power.

Increased Facility Reliance on Electrical Power

The electrical dependence of an organization increases as its functions become more complex. At the most basic level, standard building operations such as lighting, security systems, and elevators require electricity. Fire alarm and suppression systems are essential and require not only electricity but backup power supplies.

Since many healthcare facilities have resident populations, hygiene and feeding capabilities are also part of the electrical demand. Environmental controls, such as heating and air conditioning, are very important as patient populations are often susceptible to temperature changes. At higher levels of care, other important electrical loads include life-support systems, monitoring capabilities, diagnostic capabilities (e.g., radiology, laboratory), blood banking and transfusion services, morgue operations, and pharmaceutical and other supply storage.

Regulations do not mandate that emergency standby power generation be available for all existing functions. Regulations⁵ do require emergency standby power to particularly sensitive areas in hospitals, including operating rooms and critical care units where even a momentary interruption in power could mean life or death for an individual patient.

Scientific and technological advancements have both improved the care patients receive and increased healthcare facilities' reliance on electricity. One example of increased electrical load in healthcare facilities relates to electronic health records and other computer controlled systems (e.g., voice over internet phones). Electronic health records are now found in most major healthcare facilities⁶ and are critical to the care delivered. A patient's clinical status, medications, treatments, and other important parameters are all stored and ordered through these systems.

⁵ 81 FR 63859: [Medicare and Medicaid Programs: Emergency Preparedness Requirements for Medicare and Medicaid Participating Providers and Suppliers](#)

⁶ In 2015, 84 percent of all non-federal acute care hospitals had adopted a Basic Electronic Health Record with clinician notes. Office of the National Coordinator for Health Information Technology. "Non-Federal Acute Care Hospital Electronic Health Record Adoption,." Health IT Quick-Stat #47. <https://dashboard.healthit.gov/quickstats/pages/FIG-Hospital-EHR-Adoption.php>.

Given the increase in reliance on computer-controlled systems, some facilities have complex server rooms which require their own environmentally controlled support systems.

Standby Power Generation Issues

In the event of power interruption, emergency power supply systems provide emergency standby power to facilities. These systems are susceptible to design, capacity, and maintenance issues. Recurring challenges and themes are discussed below, and general information about standby power generation and utility power is available in Appendix A.

Design Issues

Emergency power supply systems are complex. When evaluating standby power capabilities, consider that each component of the system can have independent vulnerabilities. Example design issues include:

- System components (e.g., fuel pumps) located in a position where they are vulnerable to hazard impacts, such as flooding or wind.
- System components not designed to withstand hazard impacts. For example, battery-starting mechanisms and exhaust stacks not secured properly to withstand earthquake impacts.
- System components and required transfer switch not appropriately installed to safely remove the facility from grid to emergency backup power and vice versa when the power is restored.
- Untested components impacting a facility's ability to operate, for example:
 - An organization moving into a new facility and not discovering that the fuel pump for the generator was not on backup power; and
 - New facilities discovering in an emergency that red outlets (a standard indicator of outlets connected to emergency backup power) are actually not connected.

Generator System Components

- Motor and alternator
- Transfer switches
- Electrical lines
- Battery-starting mechanisms
- Fuel storage
- Fuel pump
- Fuel line
- Exhaust



Case Study: Superstorm Sandy

During Superstorm Sandy in 2012, a large hospital lost emergency power because the fuel pumps were located in the basement and under water. Without emergency power, they were unable to operate the pumps to fill storage with potable water. When the storage tanks drained, the hospital lost potable water and the patients and staff had to be evacuated. Two patients could not be evacuated, and members of the National Guard had to hand-carry fuel to the higher floors for weeks to enable portable generator power for the remaining patients.

Capacity Issues

Emergency power supply systems have a maximum electrical load that they can carry. Few facilities, especially large ones, have full redundancy of power for their total operating capacity supplied through the emergency standby generator capability. Facility administrators and

emergency managers should have a detailed account of which systems are and are not intended to draw on backup power supply.

Air conditioning systems are often not connected to backup power. Air conditioning consumes a tremendous amount of electricity. By some estimates, for the average facility, adding air conditioning to the backup electrical load will approximately double the required generator support needed. However, in some climates, lack of air conditioning⁷ is a serious threat to patient populations, particularly those with conditions that affect their ability to regulate body temperature.

A number of other systems also may not be covered by backup power:

- Environmental control for server rooms
- Diagnostic equipment including radiology
- Morgue
- Lab
- Blood bank, transfusions service, and human tissue storage
- Food preparation areas
- Elevators
- Pharmacy/floor prescription dispensaries.

Additionally, many facilities do not have enough generator capacity to continue supplying the facility in the event of a generator mechanical failure (i.e., if the facility has one generator down for repair, the remaining generators are not able to fully supply the usual power demand).

Maintenance and Resupply Issues

Even with proper preventative maintenance, mechanical failure of standby generators occurs, requiring special expertise and sometimes difficult-to-obtain critical components. Additionally, generators require a constant supply of fuel. While fuel can and often is required to be stored on site, fuel can degrade if stored for lengthy periods. Post-impact road conditions and availability of relevant resources (e.g., specialized repair personnel, critical components, fuel) all impact generator operations.

Good Practices to Overcome Challenges

A healthcare facility can take multiple measures to improve the resilience of its standby power operations. Good practices to consider are listed below.

Generator Loads

The load on a generator is determined by the various power-consuming devices attached to the emergency power supply system. Generators have a maximum load and a rated load. The rated load is lower and is the load a generator can carry for extended periods.

For any given electrical device, the load it places on a generator will vary. The highest load, the startup load, occurs when a device is turned on.

All devices supplied by the generator need to be accounted for in determining overall load.

⁷ Many larger facilities use chillers to supply air conditioning, which also depend on an intact water supply.

Systems Analysis

Facilities should undertake a vulnerability assessment of their standby power systems, to include:

- All system components and hazards likely to impact the facility.
- A detailed accounting of what electrical devices are and are not supplied by the backup power.
- The portions of the facility that will be supplied with standby power during a power interruption, as well as the portions that will not.
- A list of backup requirements from all licensing and accreditation agencies.
- A critical component – a clear understanding of fuel consumption rates while generators are on their rated load, and a conservative estimate of when refueling will be necessary.
- A load-shedding scheme in which less vital systems are powered down (load shed) to provide power to more critical systems. Appendix A outlines the three branches within an emergency distribution system (i.e., life safety, critical, equipment), which can be a method for facilities to assess the most critical functions that need to remain powered by a diminished emergency power supply.
- An advanced lifecycle analysis in which individual components are evaluated based upon life expectancy. In this manner, predicted replacement schemes can be developed.

A template assessment survey can be found at

<https://www.poweredforpatients.org/resources/reference-materials/>.



Case Study: Protecting Patients When Disaster Strikes

A Playbook for Safeguarding Emergency Power Systems for Rhode Island's Critical Healthcare Facilities during Extended Power Outages

Recognizing the crucial importance of assisting critical facilities that depend on power to provide support to the most vulnerable populations, the Rhode Island Emergency Management Agency and the Rhode Island Department of Health worked closely with the nonprofit organization Powered for Patients to develop a guide for safeguarding emergency power systems and expediting power restoration for critical healthcare facilities during and following disasters that trigger extended power outages. The Playbook includes inventory material, emergency power supply contacts, facility manager checklists, and reporting systems, along with a four-phase planning process. The phases are:

- Assessing potential power vulnerabilities and how to address them.
- Ensuring facilities have reliable emergency power, should the grid go down.
- Operating under emergency power and sustaining efforts during emergency power operations for four days or longer.
- Managing the post-disaster recovery process, and learning as an organization to prepare for subsequent emergencies.

This guide is available at <https://www.poweredforpatients.org/riema-announces-power-resiliency-initiative-for-rhode-islands-critical-healthcare-facilities/>.

Generator Maintenance

Generator maintenance is a complex topic, largely beyond the scope of this guide. However, general good practices include regular servicing, regular load tests to gauge performance, and taking steps to preserve the on-site fuel supply and prevent its degradation.

Some facilities, including hospitals and skilled nursing facilities, are required by regulation to test their generators on a regular basis. These regular tests provide healthcare facilities and local emergency managers an opportunity to complete an assessment during this process. Detailed information on generator maintenance can be found in *National Fire Protection Association 110: Standard for Emergency and Standby Power Systems*.⁸

Disconnect test

Some facilities test their standby power systems by completely disconnecting from the grid. This test accurately identifies areas that are not clearly supplied by backup power and provides an effective simulation of power outage. NOTE: A disconnect test has associated challenges and is best conducted with extensive preparations.

Vendor Supplier

Many inoperable emergency power supply systems require repair from an outside vendor. Evaluate vendors for maintenance and fuel for their ability to respond post-impact, especially when transportation routes may be affected. Additionally, consider obligations the vendors may have to other organizations during an incident to ensure they can fully support all customers.

U.S. Army Corps of Engineers (USACE) Emergency Power Facility Assessment Tool (EPFAT)

Following a disaster, it can take USACE many hours, possibly days, to deploy assessment teams to all of the impacted critical public facilities. However, USACE provides a free web-based self-assessment tool that permits facilities to input, store, and update standby power data prior to a disaster, which expedites the process if additional generator power from FEMA's temporary power assets is ever required for a facility.⁹ By some estimates, it can reduce the time to establishing additional standby power by up to 30 percent.

Uninterruptible Power Supply (UPS) Systems

Some electronic devices are very sensitive, and even the brief time to switch to backup power can cause malfunctions in equipment (e.g., reboot). UPS systems provide continuous (uninterruptible) power, often for brief periods, and typically supply critical equipment that can be adversely affected by even momentary power outages. Consider UPS systems for particularly sensitive areas (e.g., interventional cardiology).

⁸ National Fire Protection Association 110: Standard for Emergency and Stand-by Power Systems <https://www.nfpa.org/codes-and-standards/all-codes-and-standards/list-of-codes-and-standards/detail?code=110>.

⁹ Emergency Power Facility Assessment Tool: <https://epfat.usace.army.mil/>.

Generator Quick-Connect Tap Boxes

Even if a facility believes its capabilities are enough for anticipated loads, pre-establishing generator quick-connect tap boxes, also known as generator inlet boxes or docking stations, will help in the event that generators fail or additional power is ultimately needed. Generator quick-connect tap boxes provide a permanent connection point for temporary mobile power. Establish pre-determined areas to place external generators and their fuel supply.

Remote Monitoring

Some systems permit remote monitoring devices. These devices provide a constant status of generator function and early warning of malfunction. With advance warning of a potential failure, deploying government and private sector resources to repair a failing generator can be accelerated. Additionally, if the threatened emergency power supply system cannot be repaired, an early warning of pending failure can give government officials a significant head start and reduce the amount of time needed to deploy temporary generators to replace the failing ones.

The N+1 Principle

N+1 is a strategy providing redundancy to safeguard against a single component failure. In N+1 terminology, “N” stands for the minimum number of devices, such as modules, power sources, and pumps, required to perform the intended function. “N+1” stands for the minimum plus one redundant unit. For example, one large generator may supply critical loads in a building. However, when called upon, a simple failure will prevent it from operating when needed. Instead, a strategy involving two smaller generators to supply the load, with a third generator of equal size in parallel, provides N+1 redundancy. This strategy also allows a facility to take single units offline for preventative maintenance without sacrificing operations protection.

Appendix B provides a detailed list of resources to help understand and prepare for power outage incidents.

Overview of Emergency Preparedness Regulations, Codes, and Standards

Healthcare facilities are required to follow a number of regulations, codes, and standards to ensure the safety of their patients during a power outage incident. Appendix C contains links to the full text of the regulations described below, along with other pertinent standards.

Emergency Preparedness Requirements for Medicare and Medicaid Participating Providers and Suppliers (3178-F)

On September 16, 2016, the U.S. Department of Health and Human Services CMS posted the final rule titled “Emergency Preparedness Requirements for Medicare and Medicaid Participating Providers and Suppliers (3178-F)”¹⁰ in the Federal Register with an effective date of November 16, 2016. The rule required 17 categories of participating Medicare and Medicaid healthcare providers and suppliers to comply with and implement all of the emergency preparedness regulatory requirements within a year after the effective date, on November 15,

¹⁰ 81 FR 63859: <https://www.federalregister.gov/documents/2016/09/16/2016-21404/medicare-and-medicaid-programs-emergency-preparedness-requirements-for-medicare-and-medicaid>.

2017. The final rule outlines four core elements which apply to all 17 provider types, with a degree of variation based on inpatient versus outpatient. This rule requires providers and suppliers to plan adequately for both natural and manmade disasters and coordinate with Federal, state, tribal, territorial, and local public health and emergency management agencies and systems. Based on lessons learned from prior disasters and current best practices, this final rule established a comprehensive, consistent, flexible, and dynamic regulatory approach to develop an integrated emergency preparedness program. The emergency preparedness program is comprised of four required core elements:

Emergency Preparedness Checklist

CMS produced an emergency preparedness checklist intended to aid all healthcare facilities, including long-term care facilities, determine their level of preparedness and action steps.

The checklist is available at <https://www.lifespantnetwork.org/sites/default/files/EmergencyPreparednessChecklist.pdf>

- **Risk assessment and emergency planning:** Facilities are expected to develop a risk assessment using an “all-hazards” approach. The risk assessment will allow planners to develop emergency preparedness plans based on facility-specific risks.
- **Policies and procedures:** Facilities are required to develop and implement policies and procedures that support the successful execution of the emergency plan. Certain hospital and skilled nursing facilities are also required to have procedures regarding alternate sources of energy to maintain the following:
 - Temperatures to protect patient health and safety and for the safe and sanitary storage of provisions;
 - Emergency lighting;
 - Fire detection and extinguishing, and alarm systems; and
 - Sewage and waste disposal.
- **Communication plan:** Facilities are to develop and maintain an emergency preparedness communication plan. This plan must comply with Federal and state law and ensure facilities have a system to contact staff (including patients’ physicians), other necessary persons, and state and local public health and emergency management agencies to coordinate in the event of an emergency.
- **Training and testing:** Facilities are required to develop and maintain a well-organized, effective training and testing program.

Appendix C contains links to the full text of this and other healthcare requirements.



Case Study: Florida Preparedness Requirements

In addition to Federal rules, many states have regulations around preparedness. In the State of Florida, as a result of Hurricane Irma in 2017, skilled nursing facilities must provide their comprehensive emergency management plan to their local emergency management agency for review. Skilled nursing facilities and assisted living facilities also must have generators to power air-conditioning systems that can maintain an ambient temperature of no more than 81 degrees for 96 hours after an outage. NOTE: This temperature requirement does not necessarily apply to entire facilities, as facilities could move patients into key areas with cooling capabilities.

National Fire Protection Association (NFPA) 99: Health Care Facilities Code

NFPA 99 establishes criteria for levels of healthcare services or systems based on risk to patients, staff, or visitors in healthcare facilities to minimize the hazards of fire, explosion, and electricity. This code is commonly, but may not be fully, included in other Federal, state, local, tribal, or territorial regulations or building codes. The electrical systems chapter of this code outlines the performance, maintenance, and testing of electrical systems, both normal and essential, in healthcare facilities. Appendix A contains a list of the specific equipment that the code requires to be connected to standby emergency power. Appendix C provides a link to the full text of this and other NFPA codes.

Hospital Accreditation Programs

Several hospital accreditation programs (e.g., Joint Commission, Norske Veritas Healthcare, Healthcare Facilities Accreditation Program) set standards on patient, individual, or resident care, as well as organizational functions that are essential to safe high-quality care. Healthcare facilities subject to survey and certification for CMS' Medicare and Medicaid Programs may elect to participate in one of these programs to meet Federal and state regulatory program requirements. The following standard is a specific example of an applicable standard from the Joint Commission:

- **Standard EC 02.05.07** addresses hospitals' requirements to inspect, test, and maintain alternate power systems that are activated in emergencies. Electrical power supply systems may fail during a power disruption, which could leave the hospital unable to deliver safe care, treatment, and services to patients. Testing these systems increases the chances of detecting reliability problems and reduces the risk of losing this critical resource when it is most needed. Under Standard EC.02.05.07:
 - Hospitals must perform a functional test of battery-powered lights required for egress every 12 months.
 - Every quarter, hospitals should perform functional tests of stored emergency power supply systems.
 - Twelve times a year, hospitals should test emergency generators.

Considerations Regarding Regulations

Facilities Not Covered by CMS Regulations

Although the emergency preparedness requirements from CMS apply to a wide variety of facility types,¹¹ some facilities are not covered.

¹¹ The emergency preparedness requirements apply to all 17 provider and supplier types: Religious Nonmedical Health Care Institutions, Ambulatory Surgical Centers, Hospices, Psychiatric Residential Treatment Facilities, Programs for All-Inclusive Care for the Elderly, Hospitals, Transplant Centers, Long-term Care Facilities, Intermediate Care Facilities for Individuals with Intellectual Disabilities, Home Health Agencies, Comprehensive Outpatient Rehabilitation Facilities, Critical Access Hospitals, Providers of Outpatient Physical Therapy and Speech-Language Pathology Services, Community Mental Health Centers, Organ Procurement Organizations, Rural Health Clinics and Federally Qualified Health Centers, and End-Stage Renal Disease Facilities.

Non-Medical Care Providing Facilities

Facilities that do not provide skilled nursing and medical care are commonly not subject to Federal and/or state regulatory survey, certification, and oversight. Many of these facilities do not adopt or implement emergency preparedness requirements. These facilities include, but are not limited to, assisted living facilities, non-skilled nursing homes, and board and care homes. The populations of these facilities, however, can include individuals with access and functional needs and should be included in community preparedness activities and response priorities.

Small Residential Facilities

The emergency preparedness regulations apply to all 17 provider and supplier types. Some of these facilities, however, may not be subject to all of the requirements due to their size and the administrative burden. These facilities include:

- Intermediate Care Facilities for Individuals with Intellectual Disabilities;
- Psychiatric Residential Treatment Facilities;
- Programs of All-Inclusive Care for the Elderly;
- Religious Nonmedical Health Care Institutions; and
- Inpatient Hospices.

Restrictions of Use of Grant Dollars

HHS' Hospital Preparedness Program (HPP) is the only source of Federal funding specifically for healthcare delivery system readiness. HPP provides funding and leadership to states, territories, and eligible municipalities to improve patient outcomes, minimize the need for Federal and supplemental state resources during emergencies, and enable rapid recovery from catastrophic events through the development of healthcare coalitions (HCCs) ¹².

HCCs incentivize and support diverse and often competitive healthcare organizations with differing priorities and objectives to work together to save lives during disasters and emergencies that exceed the day-to-day capacity and capability of individual healthcare and emergency response systems. HPP funding must primarily support strengthening healthcare system preparedness through collaborative development of HCCs that prepare and respond as an entire regional health system, rather than individual healthcare organizations.

The HHS Office of the Assistant Secretary for Preparedness and Response permits providing direct funding from the recipient or the HCC to individual healthcare entities for regional preparedness efforts. This funding, though, is not permitted to be used to meet CMS conditions of participation, including Emergency Preparedness Requirements.

¹² An HCC is a group of individual healthcare and response organizations (e.g., hospitals, emergency medical services [EMS], emergency management organizations, public health agencies, etc.) in a defined geographic location. HCCs play a critical role in developing healthcare delivery system preparedness and response capabilities. HCCs serve as multiagency coordinating groups that support and integrate with Emergency Support Function (ESF) #8 activities in the context of incident command system responsibilities. See <https://www.phe.gov/Preparedness/planning/hpp/reports/Documents/2017-2022-healthcare-pr-capabilities.pdf>

HCCs are permitted to use HPP funding to:

- Develop the staffing capacity and technical expertise to assist their members with the development of their emergency plans;
- Develop the staffing capacity and technical expertise to assist their members with the development of policies and procedures;
- Fund the costs associated with adding new providers and suppliers who are seeking to join coalitions to coordinate patient care across providers, public health departments, and emergency systems to their HCC;
- Assist members with the development of a communication plan that integrates with the HCC's communications policies and procedures; and
- Plan and conduct trainings and exercises at the regional or HCC level.

Integrating Emergency Preparedness Efforts

During a power outage, the assistance that emergency managers and public health officials can provide to healthcare facilities is limited. Therefore, preparedness is critical. This section outlines the importance of integrated plans, methods for integrating plans, and additional preparedness opportunities.

Integrated Community-Based Planning

Planners achieve unity of purpose by coordinating and integrating plans across all levels of government, nongovernmental organizations, the private sector, and individuals and families. A shared planning community makes planning cycles more efficient and effective and can also make plan maintenance easier.

Vertical and Horizontal Integration

To be effective, organizations must integrate plans both vertically and horizontally.

- **Vertical integration** incorporates planning through various scales within a specific function. For example, healthcare facilities work with local public health and emergency managers to ensure common planning expectations. Similarly, local public health and emergency managers coordinate with state public health and emergency managers.
- **Horizontal integration** incorporates planning across various organizations and jurisdictions. For example, healthcare facilities coordinate plans with other healthcare facilities and with local utilities. The local emergency management agency, in collaboration with local public health, can facilitate this process.

Both vertical and horizontal integration build unity of effort through a common understanding of relevant capabilities, relationships, objectives, and resource requirements.



Case Study: Jacksonville-Area Hospitals in Northeast Florida in Response to Hurricane Irma

In 2017, Hurricane Irma impacted Florida counties, creating issues ranging from fuel availability to closed Interstate Highways, flooding, and power outages. However, Northeast Florida hospitals had used the lessons learned from the 2016 hurricane season to strengthen their preparedness measures and improve the response framework within the healthcare community.

Collective preparedness and response as well as detailed emergency plans helped hospitals in the Jacksonville area maintain continuity of service during Irma. Hospitals prepared in advance to maintain patients' health and well-being, focusing on emergency services as a top priority. Emergency preparedness resources, such as electrical generators, specially trained administrators and staff, and local government emergency operation centers were verified and readied to respond. Memorial and Orange Park hospitals had the resources of corporate parent Hospital Corporation of America to assist. Fuel tanks staged near Memorial Hospital were ready to refuel gas tanks of

generators when necessary. Further preparations, such as backup generators and water tankers, were deployed to hospitals as well. Lastly, additional pharmaceutical and medical supplies, along with food and essentials, were stockpiled to ensure hospitals were self-sufficient for days.

These preparations lessened the impact of Irma on emergency services. The advance planning allowed hospitals to respond rapidly to changing patient needs during Irma. Furthermore, the advance planning ensured that critical needs patients did not experience an interruption of care. The dedication of hospital staff, the planning of administration, and the resource sharing made available by local government emergency operators made all of this possible.

Integrating Plans through Synchronization

The process of integrating plans is as important as the integrated plans themselves. Integration allows organizations to know their roles, understand how plans fit together, identify and address gaps execute their plans, and coordinate activities in the event of an emergency. Plans are not scripts organizations should follow to the letter, but are flexible to adapt to actual situations. Effectively integrated plans convey the goals and objectives of the intended operation and the actions needed to achieve them. The process of integrating and synchronizing plans also builds and develops working relationships across organizations. The existence of pre-established relationships is a valuable asset in emergency incidents.

Organizations can synchronize a number of aspects of healthcare facility, utility operator, and emergency plans. Emergency management and public health agencies, healthcare facilities, and utility companies should consider making the following items common or agreed upon:

- Triggers for activating emergency response plans;
- Roles and responsibilities for all organizations;
- Operational goals and objectives;
- Pre-identified critical and co-dependent facilities¹³;
- Triggers for providing early warning at the first sign of a threat to emergency power;
- Communication methods; and
- Facts and planning assumptions.

Overview of the Power Outage Incident Annex to the Response and Recovery Federal Interagency Operational Plans (POIA)

The *Power Outage Incident Annex: Managing the Cascading Impacts from a Long-Term Power Outage* guides federal level responders in response and recovery support to state, local, tribal, territorial, and insular area efforts while ensuring the protection of privacy, civil rights, and civil liberties.¹⁴ The annex provides incident-specific information to the basic concept of operations described in the Response and Recovery Federal Interagency Operational Plans.

¹³ Healthcare has transitioned from an inpatient facility setting (e.g., hospitals) to outpatient and community-based settings. Although a patient may no longer be in a hospital, they may still be receiving life-saving and life-maintaining services (e.g., at a dialysis center, as an outpatient, at the patient's home).

¹⁴ Power Outage Incident Annex: <https://www.fema.gov/media-library/assets/documents/154058>.

The primary audience for the POIA is Federal departments and agencies that lead or support response and recovery activities in an emergency or disaster. However, much of the information in the annex is beneficial for and can be adopted or considered by planners at all levels of government and in the private and non-profit sectors. The annex provides an approach that can support integration from the Federal to local levels and inform facility planning activities in advance of a widespread or severe power outage.

Appendix B contains Federal objectives, tasks, planning assumptions, critical information requirements, and essential elements of information pertinent to prioritizing assistance to healthcare facilities during a power outage. Appendix C contains a link to the full POIA.

Additional Opportunities for Collaboration

Many ongoing community preparedness efforts could benefit by involving healthcare facilities and utilities. Including a wide range of stakeholders (e.g., government officials, first responders, utility companies, and healthcare facilities) improves overall community preparedness. Below are several examples.

Threat and Hazard Identification and Risk Assessment (THIRA) and Stakeholder Preparedness Review (SPR)

Communities use the THIRA/SPR¹⁵ to answer the following questions:

- What do we need to prepare for?
- What level of capability do we need to be prepared?
- What are our current capabilities?
- What gaps exist between the capabilities we need and the capabilities we currently have?
- How can we address our capability gaps?

By involving healthcare facilities, utility companies, and first responders in the THIRA/SPR process, emergency managers can gain a better understanding of the risks their communities face as well as the capabilities they possess.

Energy Assurance Planning

The goal of energy assurance planning is to achieve a robust, secure, and reliable energy infrastructure that is also resilient—i.e., able to restore services rapidly in the event of any disaster. Utility owners and operators are responsible for their energy infrastructures and delivery systems, but state and local officials have the responsibility to work with energy providers and stakeholders from other jurisdictions, government agencies, businesses, and related organizations to reduce consequences and provide for rapid recovery. Governments achieve this through the energy assurance planning process. More information about the energy assurance planning process is available from the National Association of State Energy Officials.¹⁶

¹⁵ THIRA/SPR guidance: <https://www.fema.gov/threat-and-hazard-identification-and-risk-assessment>.

¹⁶ State Energy Assurance Guidelines; <https://www.naseo.org/eaguidelines>.

Mitigation Planning

Mitigation planning¹⁷ identifies policies and actions that local governments can implement over the long term to reduce risk and future losses from hazards. Healthcare facilities and utility operators benefit mitigation planning in two ways. First, they can serve on the planning team itself. Second, they can participate in a smaller way, providing subject matter expertise to the planning team on specific topics such as certain protocols around power restoration.

As part of mitigation planning, jurisdictions and organizations may explore Federal, state, tribal, territorial, or other funding opportunities to develop new or upgrade existing infrastructure, research other power generation options, and enhance community power resilience. One such program is the Rural Utility Program¹⁸ from the U.S. Department of Agriculture that helps develop new and upgrade current electrical infrastructure in underserved areas.

Training and Exercise Program Workshops

Annual Training and Exercise Program Workshops¹⁹ are a chance to identify multi-year program priorities as well as the participate in training offerings and exercises necessary to accomplish these priorities. Training and Exercise Program Workshops, a requirement of several preparedness grant programs from the U.S. Department of Homeland Security (DHS), should include representatives from across the whole community. Each participating organization may also be able to provide potential training and exercise opportunities. Jurisdictions and organizations can combine many of these events for cost savings and increased coordination.

Training

Training builds the collective knowledge of the community. Training events that involve multiple stakeholder groups have significant advantages as they allow a broad range of stakeholders to meet and interact in a casual environment, share best practices and prior experiences, and gain a mutual understanding of a training topic. Appendix C lists online and in-person training opportunities available at no cost.

Exercises

Exercises are required for regulated healthcare facilities (as part of the Emergency Preparedness Requirements for Medicare and Medicaid Participating Providers and Suppliers) and for many state and local governments (as part of various grant programs). Well-designed exercises provide a low-risk environment to test capabilities, acquaint personnel with roles and responsibilities, and foster meaningful interaction and communication across organizations. Including a variety of stakeholders in exercises enables the testing and validation of plans and capabilities, and it allows for the identification of current strengths as well as capability gaps and areas for improvement.

¹⁷ Local Mitigation Planning Handbook: <https://www.fema.gov/media-library/assets/documents/31598>.

¹⁸ Rural Utility Program: <https://www.rd.usda.gov/files/RD-RUS-RBSEnergyEfficiencyComparisonChart2016.pdf>.

¹⁹ Information on Training and Exercise Program Workshops and exercise design: <https://www.fema.gov/hseep>.

Prioritizing Assistance to Healthcare Facilities During Response

Healthcare facilities should be a priority for all levels of government and the private sector during a power outage event. Patients and residents in these facilities depend on others for medical care or assistance with activities of daily living and are vulnerable to environmental changes. Prioritizing resources is a complicated, interdependent process, and should be part of the integrated planning process well in advance of an incident. This section identifies roles and responsibilities for various organizations during the response to a power outage incident. It also discusses the community lifelines construct as a method to support rapid decision making and resource prioritization during a response.

Roles and Responsibilities in Assistance Prioritization

A common understanding of the roles and responsibilities of the organizations is vital to a successful operation. All organizations need to understand the plan, their role in the plan, and the roles of other organizations in the plan. Some of the responsibilities of organizations involved in prioritizing assistance to healthcare facilities during a power outage are outlined below.

Healthcare Facilities

- Primarily responsible for the health and safety of their patients and residents, including during a power outage.
- Should register in the USACE EPFAT prior to a power outage to shorten the timeline to temporary power support in an emergency.

Healthcare Coalitions (HCCs)

Responsibilities vary by coalition but may include:

- Sharing information between HCC members and with other jurisdictional partners;
- Maintaining situational awareness;
- Sharing and coordinating resources;
- Coordinating patient movement and evacuation;
- Assisting with coordination of mass shelter operations;

USACE EPFAT

USACE is often called upon to help provide temporary emergency power at critical public facilities identified by state officials. Facility assessment data is required before a generator can be sourced and installed.

Healthcare facilities and other critical infrastructure operators can use the secure web-based EPFAT to input, store, update, and/or view temporary emergency power assessment data. Having pre-installation assessment data well in advance expedites USACE's ability to provide temporary power.

Access EPFAT at: <https://epfat.usace.army.mil/>

- Tracking patients and supporting family reunification;
- Coordinating assistance centers and call centers; and/or
- Providing staff to support emergency operations centers (EOCs).

Energy Sector

- Facility owners and operators are responsible for stabilizing and restoring normal operations at energy facilities.

State, Local, Tribal, and Territorial Governments

- Responsible for the health and welfare of their residents, communities, lands, and cultural heritage.
- Conduct pre-event identification of potential critical facilities. This identification should consider that some facilities may warrant higher prioritization than others based on factors such as patient criticality and difficulty moving patients.
- Encourage or assist licensed electricians or other appropriate personnel to perform facility assessments and enter the data into the Emergency Power Facility Assessment Tool.
- Prioritize temporary power resources.
- Primarily responsible, in coordination with energy asset owners and operators, for prioritizing the restoration of critical infrastructure (CI).
- While restoration of power is the responsibility of electric companies, electric companies may request that governments provide services to enable the power restoration process. Examples include, but are not limited to:
 - Enforcement of road closures, public safety, and security at access points;
 - Debris removal, if warranted, to enable utility companies to more quickly access damaged equipment; and
 - Logistical support for mass care and emergency assistance services and power generation equipment to enable continuity of essential services.

Federal Government

Emergency Support Function (ESF) # 3—Public Works and Engineering

ESF Coordinator and Primary Agency: USACE

- Coordinate Emergency Power Team missions with power system stabilization and restoration activities to establish priorities for emergency generator installation.

ESF #6—Mass Care, Emergency Assistance, Temporary Housing, and Human Services

ESF Coordinator and Primary Agency: DHS/FEMA and American Red Cross

- Coordinate with ESF #8 and Healthcare Coalitions to obtain status of medical facilities, maintain awareness of medical needs of any survivors being transported from medical

facilities, and develop plans to meet their needs, to include electricity-dependent medical and assistive equipment and devices and higher-level medical care staff and services.

- Provides life-sustaining services to the affected population, including hydration, feeding, and sheltering, as well as support for reunifying families.

ESF #8—Public Health and Medical Services

ESF Coordinator and Primary Agency: HHS

- Assess and prioritize healthcare facilities' reliance on power to sustain ongoing operations.
- Provide Federal assets and capabilities to support time-sensitive, life-saving, and life-sustaining public health and medical infrastructure, as well as stabilization missions to supplement state, local, tribal, territorial, and insular area response and recovery capabilities.

ESF #12 – Energy

ESF Coordinator and Primary Agency: Department of Energy (DOE)

- Assist private sector energy asset owners and operators with restoring infrastructure-related services after an incident occurs.
- Help coordinate Federal assistance and resources for timely restoration of energy services following an incident that requires a coordinated Federal response.

Using the Community Lifelines to Prioritize Assistance

In addition to having a mutual understanding of organizational roles and responsibilities during a response, all stakeholders benefit from having a common lexicon with which to describe the status of disaster impacts and a common framework for making resource prioritization decisions. The community lifelines transcend public and private sector boundaries and reframes incident information to provide decision-makers with key impact data.²⁰

By considering interdependent impacts across the lifelines, decision-makers can:

- Rapidly determine whether an incident is complicated or complex;
- Prioritize and focus response efforts to maintain or restore the most critical services and infrastructure;
- Ensure limited resources can go toward a common goal that requires involvement across the whole community; and
- Promote a response that fosters better integration and communication across the whole community since lifeline management transcends public and private sector boundaries.

There are seven lifelines: Safety and Security; Food, Water, Shelter; Health and Medical; Energy (Power & Fuel); Communications; Transportation; and Hazardous Material (Figure 1).

²⁰ Information on Community Lifelines: <https://www.fema.gov/media-library/assets/documents/177222>



Figure 1: The Seven Community Lifelines

These lifelines enable the continuous operation of government functions and critical business and are essential to human health and safety or economic security. Each lifeline is comprised of multiple components and subcomponents.

Conclusion

A wide variety of natural, technological, and human-caused threats and hazards cause power outages. Patients in hospitals, skilled nursing facilities, and long-term care facilities are at heightened risk during a power outage event. By aiding these facilities to adequately prepare for power outages, coordinating emergency response plans, and prioritizing assistance to these facilities during a power outage, communities can increase their resilience and protect lives.

Appendix A. Basics of Utility and Standby Power in Healthcare

This appendix provides a basic understanding of utility and temporary power (e.g., battery, generator power). Understanding the basics of utility and temporary power, and its limitations, is important when interfacing with utility companies, vendors, and facility engineers. The below information is from *FEMA P-1019: Emergency Power Systems for Critical Facilities: A Best Practices Approach to Improving Reliability*. Appendix C contains a link to the full text of the guide.

Overview of Utility Power Transmission and Distribution Systems

Two basic systems, referred to as transmission and distribution, carry electrical power supplied by utilities from the point of generation to the end user (Figure 2). The transmission system is the backbone of the utility grid and carries power at the wholesale level. Utility power plants connect directly to this backbone to transport power to local distribution systems and then on to the user. Transmission lines, which operate at very high voltages that range between 69,000 and 765,000 volts, carry electricity to distribution substations. Distribution lines then disperse the power to commercial, industrial, and residential customers. At the boundaries of utility coverage areas, the transmission lines connect to transmission systems of adjoining utilities.

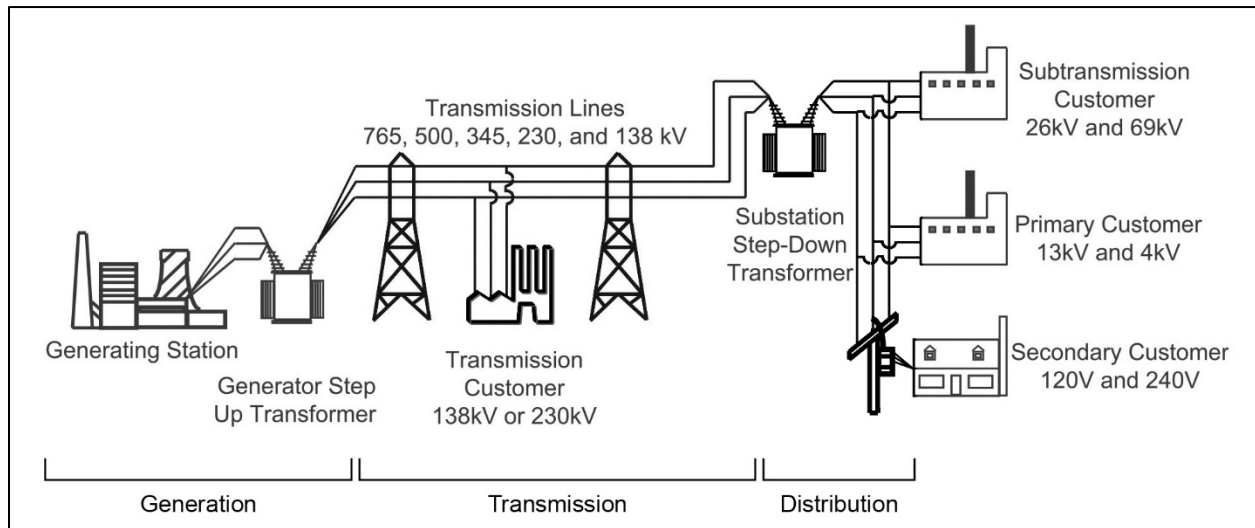

Figure 2: Illustration of a Simplified Utility Transmission and Distribution System

Failures of Transmission Systems

Similar to the inertia of a large oceangoing vessel moving at top speed, the collective inertial energy of the generators and turbines at each power plant on the utility grid stabilizes the transmission system. This is due to the enormous net inertial energy of all the connected sources. As a result, the transmission system can absorb minor disturbances from individual power plants or retail distribution load points with almost no impact to the overall utilities system.

Failures of transmission systems are unlikely but have occurred. Rare natural hazard events that spread damage over a wide geographic area have caused failures to transmission systems. When enough damage accumulates, the overall transmission system goes down, taking with it neighboring utilities in a cascading sequence of failures. Automatic protective systems may trip generating stations offline and isolate ties to neighboring utilities as network operators race to protect their systems. Recovering from such a massive outage takes days to restart power plants, reconnect major system elements, and pick up loads from local distribution systems.

Overview of Temporary Power

Power sources are devices that create (or store) electricity and ancillary equipment needed for power production and storage. The sources include stored energy devices, generators, fuel supplies, and controls for operating them. Power distribution systems deliver power from the power source to the critical equipment. The distribution system consists of switchgear or switchboards, feeders, distribution panels, panelboards, protective devices, and transfer switches.

Emergency Power Sources

In general, critical facilities employ two common methods of providing emergency power: stored energy devices, such as battery and inverter systems, and standby/emergency generators. Facility personnel must properly size, install, and maintain both types to be reliable and effective. Personnel must also supply fuel-fired generators with appropriate fuel from a reliable source.

Stored Energy Devices

Facilities frequently use stored energy devices to provide short-duration emergency power. When used alone, they often are sized to supply loads for 90 minutes, which allows safe egress from the facility. When used in conjunction with standby or emergency generators, facilities often use stored energy systems to supply power only during the time required to start an emergency or standby generator, stabilize its operation, and transfer critical load to the generator.

Emergency and Standby Generators

Emergency and standby generators serve a wide range of applications. Emergency generators consist of an engine (often called a prime mover), a synchronous generator, monitoring equipment, and controls. Generators require cooling to remove heat created by the prime mover and the generator and ventilation for the combustion air required by the prime mover.

The vast majority of emergency and standby generators operate on fossil fuels. Fuel delivery systems are critical to the reliability of fuel-fired generators. Selecting the proper fuel source is important, and many factors play into that decision, including generator consumption rates, the availability of fuels, and the ability to replenish the fuel supply after a natural hazard that blocks roads or disrupts infrastructure. Fuel sources for generators are either liquid (i.e., gasoline, diesel) or gas (i.e., propane, natural gas).

Battery Starting System

The battery starting system for a generator is an often-overlooked, critical component of the total system. The single most frequent reason for generator failure to start is its battery system.

- Install battery systems in conditioned space to avoid extreme temperatures.
- Use proper design and installation of interconnecting cables to compensate for voltage drop.
- Conduct routine maintenance to verify proper charging and that cable connections remain tight and corrosion free.

Emergency Power Distribution

The emergency power distribution system includes all wiring and equipment between the emergency or alternate power sources and the critical equipment that the sources supply. Upon sensing normal power loss, an automatic transfer switch automatically sends a start signal to the generator and monitors power quality. When the generator produces power within acceptable voltage and frequency limits, the automatic transfer switch automatically switches from normal to emergency power source.

The *NFPA 99: Health Care Facilities Code* defines three branches within an emergency distribution system:

- Life-safety branch;
- Critical branch; and
- Equipment branch.

The life-safety branch is the most important and given highest priority. Table 1–Table 4 detail the equipment that emergency power must support in each branch.

Table 1: Life-Safety Branch Equipment

Number	Item
A.	Egress lighting
B.	Exit signs and exit directional signs
C.	Hospital communications systems where used for issuing emergency-related instructions
D.	Generator set location as follows:
a.	Task illumination
b.	Battery charger for emergency battery-powered lighting unit(s)
c.	Select receptacles at the generator set location and essential electrical system transfer switch locations
E.	Elevator cab lighting, control, communications
F.	Electrically powered doors used for building egress
G.	Fire alarms and auxiliary functions of fire alarm systems complying with NFPA 72

Table 2: Critical Branch Equipment

Number	Item
A.	Task lighting and select receptacles in anesthetizing gas locations
B.	Isolated power systems in special environments
C.	Task illumination and select receptacles in patient care rooms, including infant nurseries, selected acute nursing areas, psychiatric bed areas (omit receptacles), and ward treatment rooms, medication preparation areas, pharmacy dispensing areas, and nurses' stations (unless adequately lighted by corridor luminaries)
D.	Additional specialized patient care task illumination and receptacles, where needed
E.	Nurse call systems
F.	Blood, bone, and tissue banks
G.	Telephone equipment rooms and closets
H.	Task illumination, select receptacles, and select power circuits for general care beds with at least one duplex receptacle per patient bedroom, and task illumination as required by the governing body of the healthcare facility, angiographic labs, cardiac catheterization labs, coronary care units, hemodialysis rooms or areas, emergency room treatment areas, human physiology labs, intensive care units, and postoperative recovery rooms
I.	Additional task illumination, receptacles, and select power circuits needed for effective facility operation, including single-phase fractional horsepower motors, which are permitted to be connected to the critical branch

Table 3: Equipment Branch (Automatic Connection) Equipment

Number	Item
A.	Central suction systems serving medical and surgical functions
B.	Sump pumps and other equipment required to operate for the safety of major apparatus, including associated control systems and alarms
C.	Compressed air systems serving medical and surgical functions
D.	Smoke control and stair pressurization systems
E.	Kitchen hood supply or exhaust systems, or both, if required to operate during a fire in or under the hood
F.	Supply, return, and exhaust ventilating systems for airborne infections/isolation rooms, protective environment rooms, exhaust fans for laboratory fume hoods, nuclear medicine areas where radioactive material is used, ethylene oxide evacuation, anesthetic evacuation
G.	Where delayed automatic connection is not appropriate, ventilation system shall be permitted to be placed on the Critical Branch

Table 4: Equipment Branch (Automatic or Manual Connection) Equipment

Number	Item
A.	Heating equipment for operating, delivery, labor, recovery, intensive care, coronary care, nurseries, infection/isolation rooms, emergency treatment spaces, and general patient rooms; and pressure maintenance (jockey or make-up) pump(s) for water-based fire protection systems
B.	Heating of general patient rooms during disruption of the normal source shall not be required under any of the following conditions
a.	Outside design temperature is higher than 6.7°C (+20°F)
b.	Outside design temperature is lower than 6.7°C (+20°F), where selected room(s) is provided for the needs of all confined patients [then only such room(s) need be heated]
C.	Elevator(s) selected to provide service to patient, surgical, obstetrical, and ground floors
D.	Supply, return, and exhaust ventilating systems for surgical and obstetrical delivery suites, intensive care, coronary care, nurseries, and emergency treatment spaces
E.	Hyperbaric facilities
F.	Hypobaric facilities
G.	Autoclaving equipment, which is permitted to be arranged for either automatic or manual connection to the alternate source
H.	Controls for equipment listed in NFPA 99, 6.4.2.2.4
I.	Other selected equipment

Appendix B. Excerpts from the Power Outage Incident Annex

The POIA provides guidance for Federal-level responders for response and recovery support to state, local, tribal, territorial, and insular area efforts while ensuring the protection of privacy, civil rights, and civil liberties. The annex adds incident-specific information to the basic concept of operations described in the *Response and Recovery Federal Interagency Operational Plans*.

The primary audience for the POIA is Federal departments and agencies with a role in emergency management. Much of the information contained in the annex, though, is beneficial to planners at all levels of government and the private and non-profit sectors. Below is a selection of information from the POIA that planners and emergency managers from all levels of government, utility companies, and healthcare facilities may find useful, both in integrating plans with Federal planning efforts and in developing jurisdictional and facility plans.

Federal Government Initial Objectives

For most incidents meeting the assumptions of the POIA, the Federal Government will initially prioritize core capabilities and resources to meet the following objectives:

- Facilitate power restoration and maintain other CI within geographic regions where it is anticipated power will be restored in two weeks or less;
- Stabilize and sustain CI in geographic regions that suffer the next shortest duration of power outages;
- Provide mass care services and resources to support states and tribal nations conducting the mass evacuation of survivors, including those with access and functional needs;
- Provide mass care/emergency assistance services to those who are self-evacuating;
- Selectively deliver emergency services to high-density areas or vulnerable populations who are unable to evacuate; and
- Provide law enforcement support to establish and maintain public safety and security to ensure a safe environment for infrastructure restoration.

Federal Operational Phases

Federal operations are broken into operational phases for providing coordinated Federal support to state, local, tribal, territorial, and insular area governments. To support synchronization of plans, Table 5 defines the Federal government operational phases, and the following sections list a selection of Federal tasks in each phase. For a complete listing of the Federal tasks, see the link to the full POIA in Appendix C.

Table 5: Federal Government Response Phase Definitions

Phase	Definition
Phase 1a	Normal operations
Phase 1b	Elevated threat and the development of situational awareness
Phase 1c	Credible threat of a known hazard; selected teams are alerted and resources may be pre-positioned in anticipation of support needed by the state/tribe/territory
Phase 2a	Immediate response at the state/tribe/territory/local level (some initial response from Federal entities), gaining situational awareness, and activation of operations centers
Phase 2b	Response at the Federal level, maintain situational awareness, deployment/employment of resources to incident support bases, Federal staging areas, and identified delivery sites, and the movement of resources to incident support bases
Phase 2c	Sustained response, employment of resources at the incident site, saving lives, sheltering survivors and restoring critical systems such as power and communications
Phase 3a	Recovery activities that occur as part of the response mission area to facilitate the transition and support to the recovery mission area

Phase 1a – Normal Operations

DOE, as the Sector Specific Agency (SSA) and lead Federal agency for the energy sector, coordinates the following preparedness actions within the energy sector:

- Assists the states in preparing state energy assurance plans to improve the reliability and resiliency of the nation’s energy systems, and maintains the Energy Emergency Assurance Coordinators (EEAC) Program, contact list, and database;
- Conducts national security emergency preparedness planning, including developing capabilities, administering operational programs for all energy resources, and conducting energy emergency exercises with the energy industry, Federal partners, and state, local, tribal, territorial, and insular area governments; and
- Develops, tests, trains, and exercises continuity programs and plans, coordinating with whole community partners and stakeholders.

DOE coordinates the following activities with state, local, tribal, territorial and insular area governments:

- Conducts preparedness activities that support response and recovery to power outages, such as exercises, training, and plan development, consistent with their emergency operations and continuity plans;
- Involves local disability stakeholders in emergency planning to accurately and adequately incorporate considerations of individuals with a disability²¹ during a long-term power outage;

²¹ Individual with a Disability: Individual who has a physical or mental impairment that substantially limits one or more major life activities (an “actual disability”), or a record of a physical or mental impairment that substantially limits a major life activity (“record of”), or an actual or perceived impairment, whether or not the impairment limits or is perceived to limit a major life activity, that is not both transitory and minor (“regarded as”).

- Develops inclusive engagement strategies with the public and private utility companies in their state or jurisdiction; and
- Ensures local and state emergency operations plans include fuel action plans that identify priority users, staging areas, and daily fuel consumption by type of critical facility.

In preparation for power outages, utilities participate in preparedness activities such as:

- Contingency and continuity planning and exercises for restoration;
- Educating state EOC personnel on energy restoration and importance of right-of-way programs;
- Validating contact information for state, local, tribal, territorial, and insular area partners;
- Hardening infrastructure, inspections, and assessments;
- Ensuring that standing contracts with diesel fuel suppliers are in place.;
- Developing restoration priorities;
- Developing smart grids and micro grids;
- Developing contracts (e.g., for suppliers);
- Improving resiliency; and
- Developing mutual assistance agreements.

Phase 1b and 1c – Elevated and Credible Threats

State, local, tribal, territorial, and insular area governments should:

- Coordinate with their public utility commissions;
- Identify potential waivers that may be required to expedite disaster response; and
- Review local and state plans for energy restoration and prioritization.

Utility owners and operators also take preventative actions depending on the credibility and likelihood of a threat to the electric grid. They:

- Review and reassess their critical asset list and rank assets for restoration priority; and
- Identify and position resources to respond to an outage, and implement a plan to prioritize response actions (i.e., those that have immediate threat to life or property loss such as downed live wires, and restoring emergency and hospital services).

Phase 2a and 2b – Immediate Response and Deployment

Immediate response includes actions taken within 72 hours of a notice or no-notice incident resulting in a power outage.

State, local, tribal, territorial, and insular area governments:

- Develop prioritized lists of CI for temporary emergency power.

During these subphases, public and private electric companies:

- Request assistance from state, local, tribal, or territorial governments and health and human services, including stakeholders who can provide immediate real-time information and situational awareness about people with access and functional needs who may depend on power for life maintenance and/or to mitigate personal health and safety issues (such as those living independently and/or group or some facility settings); and
- Prioritize plans and actions to restore energy during response and recovery operations.

Phase 3 – Recovery

Recovery planning and coordination for all phases of recovery (short-term, intermediate, and long-term) begin with the event and response. Actions during this phase are likely to include continuing to identify and facilitate Federal mechanisms to expedite CI restoration (e.g., Defense Production Act to prioritize contracts, regulatory relief, and restoration logistics support).

Facts, Planning Assumptions, and Critical Considerations to Aid in Planning for Prioritizing Assistance

The POIA contains facts, planning assumptions, and critical considerations that can aid all emergency managers in planning to prioritize assistance to healthcare facilities during a power outage. Below is a selection of the most pertinent of considerations. A link to the entire annex is in Appendix C.

Facts

- People with disabilities comprise about 20 percent of the national population.
- People with access and functional needs generally comprise about 30 to 50 percent of the population (NOTE: This number includes the 20 percent of people with disabilities).

Planning Assumptions

- Healthcare facilities consume fuel at approximately the rate listed in Table 6.

Table 6: Daily Fuel Consumption by Healthcare and Public Health Sector Facilities²²

Type of Facility	Generator Size	Fuel Requirement in Gallons (low)	Fuel Requirement in Gallons (high)
Hospitals	800kW–2mW	1344	2000
Nursing Homes	100–200kW	168	336
Urgent Care	200–300kW	336	504
Dialysis Center	200–300kW	336	504
Medical Center	200–300kW	336	504
Morgue	100–200kW	168	336

²² Of note, these projected fuel requirements are for a single generator. Planners should identify the correct number of generators for specific facilities. Large hospitals could have dozens.

- Critical healthcare facilities, sites such as hospitals, may have difficulty maintaining sufficient temporary emergency power and will face stress from a surge in care needs and potential degradation of services.
- Restoration Priorities – Typically, utilities adhere to the following repair and restoration sequencing:
 - Power plants
 - Startup power
 - Large transmission lines and substations
 - Distribution substations and feeder lines
 - Restoration to CI facilities
 - Residential areas

Critical Considerations (for Crisis Action Planning)

General Consideration

- Lack of inclusion for people who depend on power to sustain life or to maintain quality of life, health, safety, and independence unnecessarily places people who need assistance in a higher category of risk and increases likely rescue and response requirements.

Continuity of Operations and Government

- Robust continuity programs and capabilities mitigate impacts to the performance of essential functions, core capabilities, and critical services, as well as expedite the recovery and full resumption of impacted operations.
- Public and private sector organizations impacted by long-term power outages will require the activation of continuity plans to sustain essential functions and provide critical services to the affected population and to ensure continuity of government at all levels.
- Decision-making and coordination processes among government officials and with the heads of public and private CI sectors and other nongovernmental organizations are necessary to ensure support to response and recovery efforts. This coordination will require resilient communications capabilities.

Fuel/Generator Considerations

- Fuel should be prioritized for distribution and use based on requirements, such as the number of available generators, number of CI facilities requiring fuel or generators, and fuel consumption.
- Providing temporary emergency power to a CI facility is not the sole factor in returning the facility to normal operating status (e.g., lack of supplies, time to restart operations).
- The failure rate of backup generators will increase to approximately 15 percent after 24 hours of continuous use.
- Backup generators at some CI facilities may not be tested frequently or maintained consistently, which may result in equipment failures.
- Diesel fuel stored for more than 12 months begins to form sediments and gums. Diesel fuel used after it has exceeded its shelf life will increase the likelihood of damage to the generator.

- Use of points of distribution (PODs) may not be a feasible approach for providing fuel to critical CI facilities at fixed locations. As a result, a fuel delivery strategy will need to take into account fuel transportation requirements.

Public Health and Medical Considerations

- Healthcare services typically operate on just-in-time inventory, which may affect patient care.
- Individuals who rely on durable medical equipment and implantable devices requiring either electric power or battery recharging may lose their life-sustaining independence and overwhelm healthcare facilities if the power is out for more than a few days.
- Dialysis centers generally do not have backup generators, but often operate within a network and may shift patients to other local network facilities if the receiving facilities have power and essential medical staff, accessible transportation services are available, and costs are not prohibitive.
- Health systems must plan for crisis standards of care and scarce resource utilization during mass power outages.
- A segment of the U.S. population operates power-dependent durable medical equipment and, as a result, is unable to self-relocate during a mass power outage.²³

Critical Information Requirements and Essential Elements of Information for Prioritizing Assistance

To enable decision-making and prioritize assistance to healthcare facilities, leaders need access to key information. The POIA identifies the following critical information requirements²⁴ and essential elements of information²⁵ to help prioritize assistance during a power outage.

Critical Information Requirements

- **Incident Characterization:** Demographic information of the affected population, including vulnerable populations on utility registries that may need assistance.
- **Resource Availability:** Generator/fuel status for critical assets across each of the 16 CI sectors and any additional interagency needs to support essential functions and services.
- **Sheltering, Feeding, and Distribution of Emergency Supplies:** Names and statuses of healthcare facilities (e.g., nursing homes, dialysis facilities) in the impacted area.

²³ Beyond basic durable medical equipment, there may be many in the community receiving care by home health care providers and visiting nurses who rely on electrically powered equipment to assist with fluids, oxygen, feeding, medications and other required bodily functions. Many that fall into this group may not be mobile, and could not be transported via wheelchair lift onto a bus. When evacuation is required, may not have the healthcare provider support or have medical transport available.

²⁴ Critical information requirements facilitate timely command, control, and coordination of decisions during disaster operations. They provide insight into important details that response personnel need to effectively make decisions and execute their operations. The verification code for this document is 420930

²⁵ Essential elements of information support the critical information requirements by providing more detail for situational awareness and decision-making.

- **Hospitals in Affected Area:**
 - Patient counts and bed availability;
 - Generator and fuel status to keep facilities running;
 - Which departments are offline or hampered;
 - Status of blood, tissue, and other biologics supply;
 - Status of medications and medical supply;
 - Staff availability and/or relocation;
 - Status of health clinics in affected areas;
 - Which hospitals are open and for what services; and
 - Emergency communications and infrastructure restoration to maintain response capabilities.
- **Additional Information:**
 - Whether the needs of populations with medical, behavioral health, and social service are fulfilled;
 - Whether people with access and/or functional needs have the resources required to maintain their independence and health and wellness;
 - Whether jails and prisons can provide the necessary medical care;
 - Status of Emergency Medical Services in the area, including response and transport times of patients;
 - Fuel status;
 - Availability of mental health resources;
 - Status of oxygen producers in affected areas;
 - Drug- and alcohol-dependent related arrests and disturbances; and
 - Morgue availability.

Essential Elements of Information

Essential Elements of Information for the Government

- Maps/information on CI specific to the incident area.
- Location and status of critical healthcare facilities and services (e.g., hospitals, nursing homes, dialysis) and information on those with access and functional needs and their medical and social services needs.
- Areas with the projected shortest duration of power outage.

Essential Elements of Information for the Electricity Subsector

- List of critical facilities to use in prioritizing restoration.
- Prioritization for state, local, tribal, territorial, insular area, or Federal governments.
- Identification of critical needs to aid in prioritizing restoration efforts (e.g., water, emergency services, hospitals, shelters).

Appendix C. Resources

This appendix provides a detailed list of resources to help understand and prepare for power outage incidents.

Healthcare Emergency Preparedness Regulations and Standards

- **CMS-3178-F: Medicare and Medicaid Programs: Emergency Preparedness Requirements for Medicare and Medicaid Participating Providers and Suppliers:** Establishes national emergency preparedness requirements for Medicare and Medicaid participating providers and suppliers to plan adequately for both natural and manmade disasters. It also requires providers and suppliers to coordinate with Federal, state, tribal, regional, and local emergency preparedness systems. (<https://www.federalregister.gov/documents/2016/09/16/2016-21404/medicare-and-medicaid-programs-emergency-preparedness-requirements-for-medicare-and-medicaid>)
- **CMS-3277-F: Medicare and Medicaid Programs: Fire Safety Requirements for Certain Healthcare Facilities:** Amended the fire safety standards for Medicare and Medicaid participating hospitals, critical access hospitals, long-term care facilities, intermediate-care facilities for individuals with intellectual disabilities, ambulatory surgery centers, hospices which provide inpatient services, religious nonmedical healthcare institutions, and programs of all-inclusive care for the elderly facilities. (<https://www.federalregister.gov/documents/2016/05/04/2016-10043/medicare-and-medicaid-programs-fire-safety-requirements-for-certain-health-care-facilities>)
- **NFPA 99 – Health Care Facilities Code:** Establishes criteria for levels of healthcare services or systems based on risk to the patients, staff, or visitors in healthcare facilities to minimize the hazards of fire, explosion, and electricity. (<https://www.nfpa.org/codes-and-standards/all-codes-and-standards/list-of-codes-and-standards/detail?code=99>)
- **NFPA 101 – Life Safety Code:** The most widely used source for strategies to protect people based on building construction, protection, and occupancy features that minimize the effects of fire and related hazards. (<https://www.nfpa.org/codes-and-standards/all-codes-and-standards/list-of-codes-and-standards/detail?code=101>)
- **NFPA 110 – Standard for Emergency and Standby Power Systems:** Covers performance requirements for emergency and standby power systems providing an alternate source of electrical power in buildings and facilities in the event that normal electrical power source fails. (<https://www.nfpa.org/codes-and-standards/all-codes-and-standards/list-of-codes-and-standards/detail?code=110>)
- **International Building Code:** The minimum requirements to safeguard the public health, safety, and general welfare of occupants of new and existing buildings. (<https://www.iccsafe.org/codes-tech-support/codes/the-i-codes/>)

Guidance

- **Power Outage Incident Annex to the Response and Recovery Federal Interagency Operational Plan:** Guidance for Federal-level responders to provide response and recovery support to state, local, tribal, territorial, and insular area efforts during a long-term power outage. Much of the information in this annex is beneficial to planners at all levels of government and the private and non-profit sectors. (<https://www.fema.gov/media-library/assets/documents/154058>)
- **FEMA P-1019: Emergency Power Systems for Critical Facilities: A Best Practices Approach to Improving Reliability:** Guidance on the design and operation of emergency power systems in critical facilities so that they will be able to remain operational for extended periods, as needed. (<https://www.fema.gov/media-library/assets/documents/101996>)
- **FEMA 543: Design Guide for Improving Critical Facility Safety from Flooding and High Winds: Providing Protection to People and Buildings:** Information and guidelines for building professionals and decision-makers to implement a variety of mitigation measures to reduce the vulnerability to damage and disruption of operations during severe flooding and high-wind events. (<https://www.fema.gov/media-library/assets/documents/8811>)
- **FEMA 577: Design Guide for Improving Hospital Safety in Earthquakes, Floods, and High Winds: Providing Protection to People and Buildings:** State-of-the-art knowledge on the variety of vulnerabilities faced by hospitals exposed to earthquakes, flooding, and high-wind risks, as well as the best ways to mitigate the risk of damage and disruption of hospital operations caused by these events. (<https://www.fema.gov/media-library/assets/documents/10672>)
- **Continuity Guidance Circular:** Outlines whole community continuity planning principles and guidance, inclusive of hospitals and nursing homes, to ensure the continuation of essential functions. (<https://www.fema.gov/continuity-guidance-circular-cgc>)
- **Community Lifelines Implementation Toolkit:** Information and resources for whole community partners to understand lifelines and coordinate with entities using lifelines. It provides basic guidance for how to implement the lifeline construct during incident response. (<https://www.fema.gov/media-library/assets/documents/177222>)
- **Comprehensive Preparedness Guide 101:** Guidelines on developing emergency operations plans. It promotes a common understanding of the fundamentals of risk-informed planning and decision making to help planners examine a hazard or threat and produce integrated, coordinated, and synchronized plans. (<https://www.fema.gov/media-library/assets/documents/25975>)
- **Comprehensive Preparedness Guide 201:** Guidance for conducting the three-step process for a THIRA and the three-step process for an SPR. (<https://www.fema.gov/media-library/assets/documents/165308>)
- **State Energy Assurance Guidelines:** Informs governments on how energy assurance can improve planning for and response to energy emergencies, enhance the resiliency of response capability, reduce risks and vulnerability of critical energy infrastructure, and support investments in the resiliency of the energy infrastructure. (<https://www.naseo.org/eaguidelines>)

- **National Institute of Standards and Technology Community Resilience Planning Guide for Buildings and Infrastructure Systems:** A methodology for local government to bring together all of the relevant stakeholders to establish performance goals to maintain the social and economic fabric when disruptive events occur; in other words, to be resilient. (https://ws680.nist.gov/publication/get_pdf.cfm?pub_id=918551)
- **National Mass Care Strategy:** National Mass Care Strategy provides a unified approach to the delivery of mass care services by establishing common goals, fostering inclusive collaborative planning and identifying resource needs to build the national mass care capacity engaging the whole community including under-served and vulnerable populations. (<http://nationalmasscarestrategy.org/>)

Information

ASPR Technical Resources, Assistance Center, and Information Exchange (TRACIE)

The HHS ASPR created the TRACIE to meet the information and technical assistance needs of regional ASPR staff, healthcare coalitions, healthcare entities, healthcare providers, emergency managers, public health practitioners, and others working in disaster medicine, healthcare systems preparedness, and public health preparedness. Resource collections include:

- **Considerations for Oxygen Therapy in Disasters.** Information on the types of oxygen therapy and the types of oxygen supplies generally available, as well as typical sizes and length of use of various oxygen storage methods. (<https://files.asprtracie.hhs.gov/documents/aspr-tracie-ta-oxygen-therapy.pdf>)
- **Durable Medical Equipment in Disasters.** Information on general durable medical equipment (DME) categories; focuses on electricity-dependent DME that may be affected by disasters and emergencies, including power failures. Includes information to help healthcare system preparedness stakeholders plan for medically vulnerable populations who rely on DME. (<https://files.asprtracie.hhs.gov/documents/aspr-tracie-durable-medical-equipment-in-disasters.pdf>)
- **Emergency Preparedness Requirements for Medicare and Medicaid Participating Providers and Suppliers:** Links to resources that can help providers and suppliers comply with the CMS Emergency Preparedness Rule. (<https://asprtracie.hhs.gov/cmsrule>)
- **Going with No Flow: Coping with Hospital Water Supply Issues:** Highlights MedStar Washington Hospital Center's response to a 2018 water outage. (<https://files.asprtracie.hhs.gov/documents/aspr-tracie-medstar-water-emergency-response-2018.pdf>)
- **Topic Collection: Continuity of Operations/Failure Plan:** Highlights selected plans and planning guidance, lessons learned, tools, and promising practices for healthcare facility continuity of operations. (<https://asprtracie.hhs.gov/technical-resources/17/continuity-of-operations-coop-failure-plan/16>)
- **Topic Collection: Utility Failures:** Lessons learned from recent disasters, case studies, and toolkits to help healthcare planners prepare to respond to, continue functioning during, and

recover from post-disaster utility failures. (<https://asprtracie.hhs.gov/technical-resources/35/utility-failures/27>)

Energy Assurance Reference Library

The National Association of State Energy Officials, with the assistance of the National Association of Regulatory Utility Commissioners under the direction of the DOE, developed the State Energy Assurance Guidelines. This reference library provides key information to aid in drafting energy assurance plans.

- **Documents and Reports:** Energy assurance Federal resources and documents and reports relevant to energy assurance planning. (<https://www.naseo.org/ea-documents-reports>)
- **EA Documents – Cybersecurity:** Energy assurance resources specific to cybersecurity. (<https://www.naseo.org/ea-documents-cybersecurity>)

Other Informational Resources

- **Continuity Resource Toolkit:** A collection of online resources to help implement the concepts in the Continuity Guidance Circular. (<https://www.fema.gov/continuity-resource-toolkit>)
- **Continuity Risk Toolkit:** General information on risk and techniques that organizations may use to perform risk analysis. (<https://www.fema.gov/media-library/assets/documents/158254>)
- **Temporary Emergency Power (video):** Explains USACE’s temporary power mission during disasters. (<https://www.youtube.com/watch?v=cOGaPw1xu0w>)
- **Roadmap to Resiliency:** Discusses emergency power best practices from the Healthcare Leadership Initiative on Maintenance of Power (from the American Society for Healthcare Engineering and Powered for Patients). (<https://www.poweredforpatients.org/wp-content/uploads/2017/03/Roadmap-to-Resiliency-ASHE-Powered-for-Patients-White-Paper.pdf>)

Training

Online Training

- **IS-815: ABCs of Temporary Emergency Power:** Acquaints members of various communities of practice (e.g., emergency management, public works, water/wastewater, healthcare) with requirements related to providing temporary emergency power to their facilities following disruption of the commercial power grid. (<https://training.fema.gov/is/courseoverview.aspx?code=IS-815>)
- **IS-547.A: Introduction to Continuity of Operations:** A more in-depth introduction to continuity planning. (<https://training.fema.gov/is/courseoverview.aspx?code=IS-547.a>)
- **IS-368: Including People with Disabilities and Others with Access and Functional Needs in Disaster Operations:** Increases awareness and understanding of the need for full inclusion of disaster survivors and staff who have disabilities or access and functional needs. (<https://training.fema.gov/is/courseoverview.aspx?code=IS-368>)

- **IS-909: Community Preparedness – Implementing Simple Activities for Everyone:** Presents a model program for community preparedness. It includes 16 Preparedness Modules ranging from 20 to 90 minutes that jurisdictions can deliver to community groups. (<https://training.fema.gov/is/courseoverview.aspx?code=IS-909>)
- **HHS emPOWER Program Web-Based Training:** Helps partners understand the HHS emPOWER Program and integrate its tools into their emergency preparedness, response, recovery, and mitigation activities. Provides a comprehensive introduction to the program, detailed overview of each of the mapping and dataset tools and examples of how public health authorities and their partners can use them, and case studies from real-world emergencies. (<https://www.train.org/main/course/1083714>)

In-person Training

The National Training and Education Division within FEMA prepares state and local first responders to prevent, protect, respond to, and recover from manmade and natural catastrophic events. Training is also provided to the private sector and the general public. FEMA provides training throughout the year. To find out more information on the following courses, course eligibility, or registration, visit <https://www.firstrespondertraining.gov/frts/npcc>.

- **E/L/G 557: Mission Essential Functions Workshop (Continuity Guidance)** (two days): Assists participants in identifying essential functions, conducting a business process analysis, and conducting a business impact analysis. (<https://www.firstrespondertraining.gov/frts/npccatalog?id=2153>)
- **MGT 454: Healthcare Coalition Response Leadership** (three days): Instruction and facilitated discussion in best practices and lessons learned in establishing an effective healthcare-coalition framework and conducting healthcare-coalition planning, as well as developing indicators, triggers, and tactics for proactive coalition planning. (<https://cdp.dhs.gov/find-training/course/MGT-454>)
- **AWR 900: Framework for Healthcare Emergency Management** (four days): For personnel who are responsible for developing, implementing, maintaining, and administering emergency management programs and plans for healthcare facilities/systems. (<https://cdp.dhs.gov/find-training/course/AWR-900>)
- **MGT 317: Disaster Management for Public Services** (two days): A unique chance for public service professionals to extend their knowledge and skills necessary for protecting their communities and infrastructure from potential or actual threats. Participants work together in multidisciplinary teams to apply the course information with their professional experience in a variety of hands-on, small group activities and disaster scenarios. (<https://www.firstrespondertraining.gov/frts/npccatalog?id=256>)
- **MGT 341: Disaster Preparedness for Hospitals and Healthcare Organizations within the Community Infrastructure** (two days): Brings together individuals from the hospital and healthcare community who ensure the resiliency of healthcare services during a high consequence or catastrophic event within a jurisdiction. Through a focus on preparedness processes and activities, this course provides a chance for participants to acquire the knowledge, skills, and abilities necessary to help them ensure the sustainability of their facilities and organizations during all types of disasters. (<https://www.firstrespondertraining.gov/frt/npccatalog?courseId=401>)

- **MGT 315: Critical Asset Risk Management** (two days): Assists local emergency responders and stakeholders in identifying CI sectors that may be at risk in their jurisdictions and helps them develop mitigation strategies that can lessen jurisdictional impacts. (<https://www.firstrespondertraining.gov/frt/npccatalog?courseId=254>)
- **MGT 345: Disaster Management for Electric Power Systems** (two days): Trains electric systems managers and employees to prepare for, protect against, respond to, recover from, and mitigate against natural disasters, technological disasters, and human-caused incidents that affect or threaten electric power facilities and systems. (<https://www.firstrespondertraining.gov/frt/npccatalog?courseId=286>)
- **MGT 409: Community Healthcare Planning and Response to Disasters** (two days): Provides medium- to high-level decision makers with comprehensive planning tools to mitigate impacts on communities during large-scale incidents. (<https://www.firstrespondertraining.gov/frt/npccatalog?courseId=1083>)
- **MGT 439: Pediatric Disaster Response and Emergency Preparedness** (two days): Prepares students to effectively, appropriately, and safely plan for and respond to a disaster incident involving children, addressing the specific needs of pediatric patients in the event of a community based-incident. (<https://www.firstrespondertraining.gov/frt/npccatalog?courseId=1781>)
- **MGT 342: Strategic Overview of Disaster Management for Water and Wastewater Utilities** (one day): A strategic overview of disaster management for water and wastewater professionals. It presents information regarding preparing for and responding to natural or human-caused disasters that threaten water and wastewater facilities and systems. (<https://www.firstrespondertraining.gov/frt/npccatalog?courseId=283>)
- **MGT 343: Disaster Management for Water and Wastewater Utilities** (two days): Training for water and wastewater professionals on issues concerning preparing for, mitigating against, responding to, and recovering from natural or human-caused disasters that threaten water and wastewater facilities and systems. (<https://www.firstrespondertraining.gov/frt/npccatalog?courseId=284>)

Modeling Tools

- **HHS emPOWER Map and REST Service Tool:** An interactive online mapping tool to help public health, healthcare, emergency management officials, and first responders better anticipate, plan for, and respond to the needs of at-risk individuals that rely on electricity-dependent medical and assistive equipment and devices to live independently in their homes. (<https://empowermap.hhs.gov/>)
- **HHS emPOWER Map REST Service:** Presents the de-identified Medicare data displayed on the HHS emPOWER Map as a Representational State Transfer (REST) Service via ASPR's GeoHEALTH Platform. Users can readily access, consume, and apply the map data layer in their own geographic information system (GIS) application to support national, state, local, territorial, and community-based GIS analyses. Public health, healthcare, emergency management, first responders, utilities, health information technology professionals, and many other community partners can use the data layer to map the number of electricity-dependent individuals in an area against hospital and shelter locations, evacuation routes, and more to inform emergency preparedness, response, recovery and mitigation efforts.

(https://geohealth.hhs.gov/dataaccess/rest/services/HHS_emPOWER_REST_Service_Public/MapServer)

- **USACE Emergency Power Facility Assessment Tool (EPFAT):** A secure web-based tool used by critical public facility owners/operators or emergency response agencies to input, store, and update important details about a facility's emergency power system to expedite deployment of temporary FEMA emergency power assets, which are available during Stafford Act Declaration events. (<https://epfat.usace.army.mil/>)
- **Renewable Energy Integration & Optimization (REopt) Lite:** Helps commercial building managers estimate how long a system can sustain critical loads during a grid outage; evaluate the economic viability of grid-connected photovoltaic, wind, and battery storage at a site; and identify system sizes and battery dispatch strategies to minimize energy costs. (<https://reopt.nrel.gov/tool>)

Appendix D. Acronym List

ASPR	HHS Office of the Assistant Secretary for Preparedness and Response
CI	Critical infrastructure
CMS	Centers for Medicare and Medicaid Services
CPG	Comprehensive Preparedness Guide
DHS	Department of Homeland Security
DME	Durable medical equipment
DOE	Department of Energy
EEAC	Energy Emergency Assurance Coordinators
EOC	Emergency Operations Center
EPFAT	Emergency Power Facility Assessment Tool
ESF	Emergency Support Function
FEMA	Federal Emergency Management Agency
GIS	Geographic Information System
HCC	Healthcare coalition
HHS	Department of Health and Human Services
HPP	Hospital Preparedness Program
NFPA	National Fire Protection Association
NIST	National Institute of Standards and Technology
POIA	Power Outage Incident Annex
REST	Representational State Transfer
SPR	Stakeholder Preparedness Review
SSA	Sector Specific Agency
THIRA	Threat and Hazard Identification and Risk Assessment
TRACIE	Technical Resources, Assistance Center, and Information Exchange
UPS	Uninterruptible Power Supply
USACE	U.S. Army Corps of Engineers